

# Technical Notes

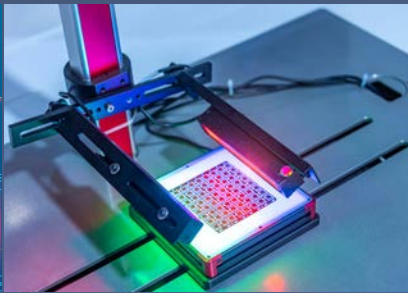

53 /  
SMD Tape  
Specifications

61 /  
Recommended  
Soldering Pattern

65 /  
Technical Data

78 /  
Bin Code Systems

80 /  
Application Notes

85 /  
CIE Chromaticity  
Diagram

87 /  
Index

## SMD TAPE SPECIFICATIONS

Reel Dimensions / Part Number								
<b>7" (for 8mm width tape) (black)</b>			<b>7" (for 8mm width tape) (white)</b>					
AA1608	APGF1012	APT1608	AA2810A	APB3025	APD3224	APGF0606	APT2012	APTL3216
AP1608	APHB1608	APTB1612	AA3021	APB3227	APDA1806	APHBM2012	APT3216	APTL3216xxx01
APG0603	APHF1608	APTD1608	AP2012	APBA3010	APDA3020	APHCM2012	APTB1615	APTR3216
APG1005	APHHS1005		APA1606	APBD3224	APFA2507	APL3015	APTD2012	
APG1608	APHM1608		APA2107	APBDA3020	APFA3010	APPA3010	APTD3216	
			APA3010	APBL3025	APFA3011	APS3227	APTF1616	
<b>7" (for 12mm width tape)</b>			<b>13" (for 24mm width tape)</b>		<b>13" (for 32mm width tape)</b>		<b>15" (for 16mm width tape)</b>	
AA3527A	AAA3528	AM2520xxx09	ACSX02-41	ACSX04-41	ACSX56-41		AB354NT	AB817-B
AA3528	AAA3528xxx09	APF3236	ACSX03-41				AB356NT	ARB011
AA3528xxx09	AAAF5050	ATIR0711S					AB357NT	ARB031A
AA4040	AM2520xxx03	ATIR0721DS					AB814-B	

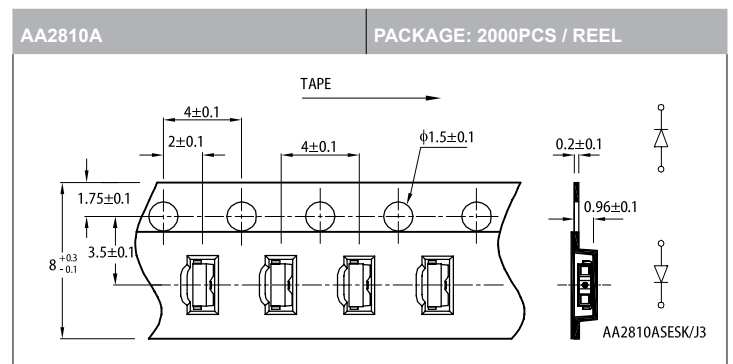
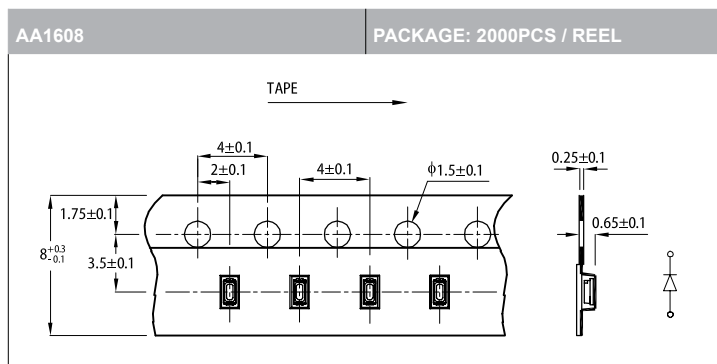
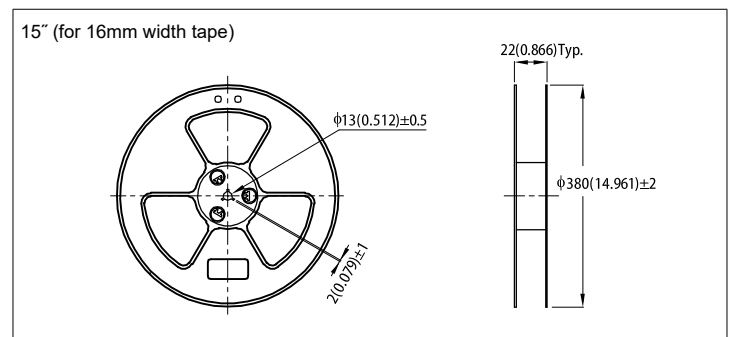
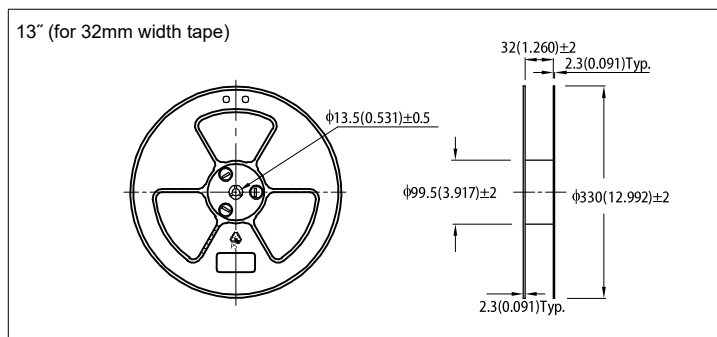
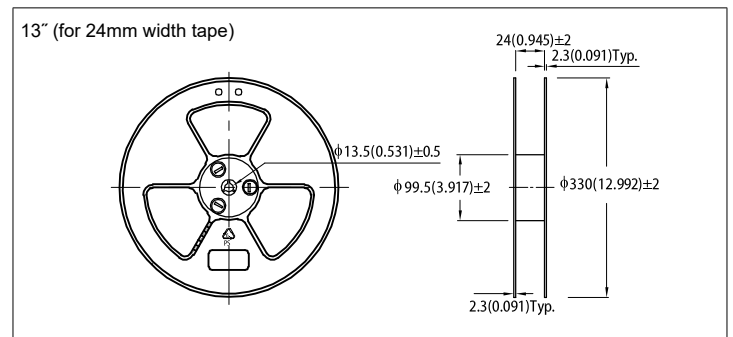
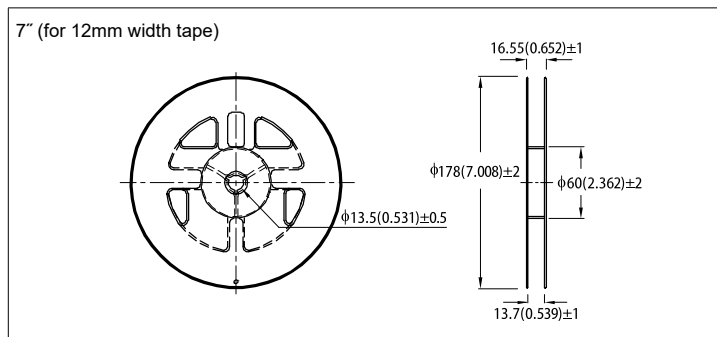
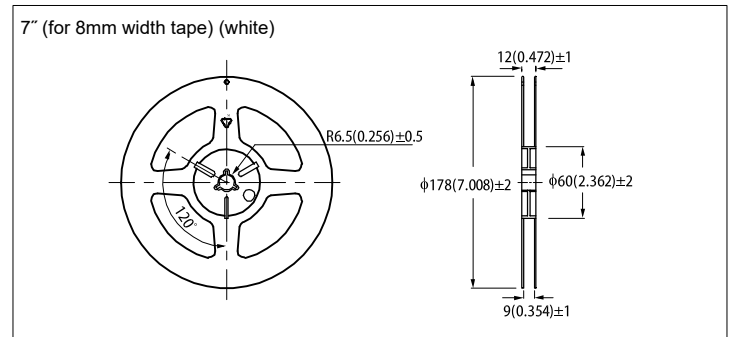
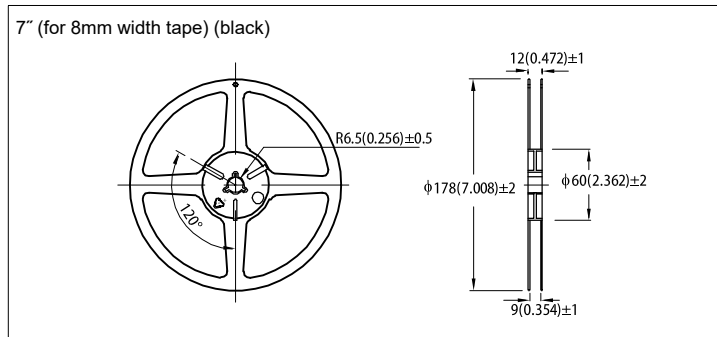

All dimensions are in millimeters

SMD TAPE SPECIFICATIONS

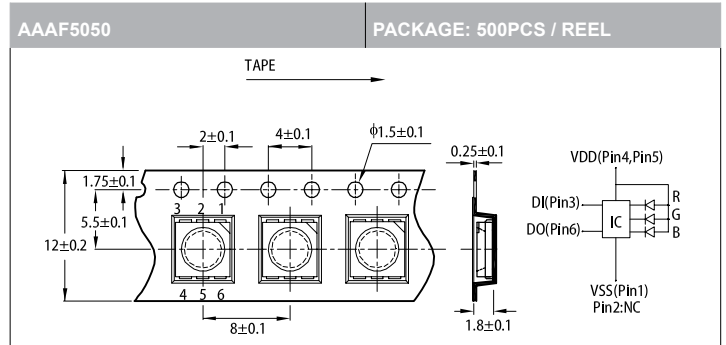
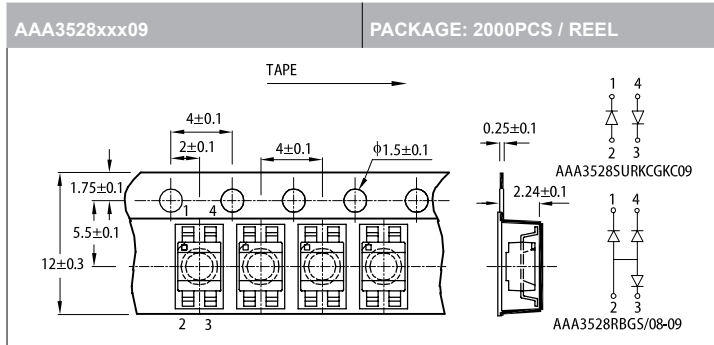
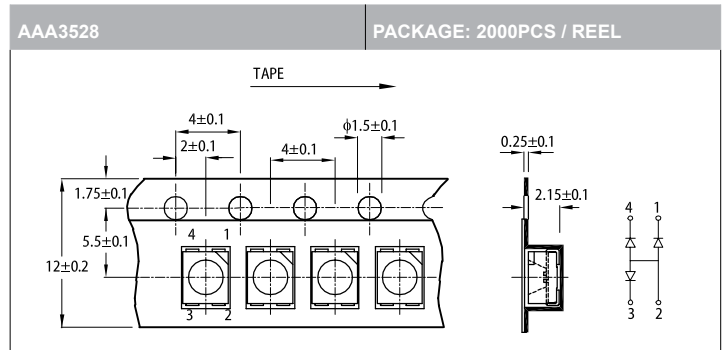
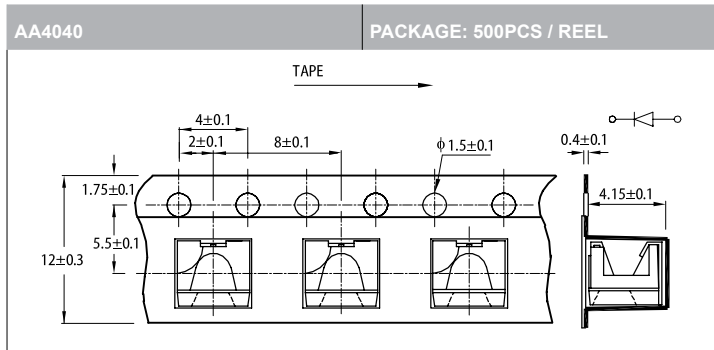
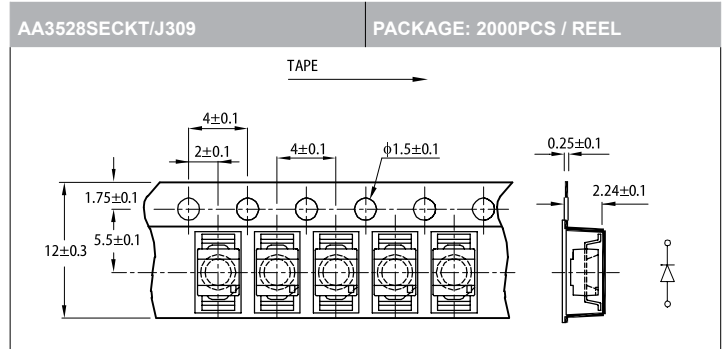
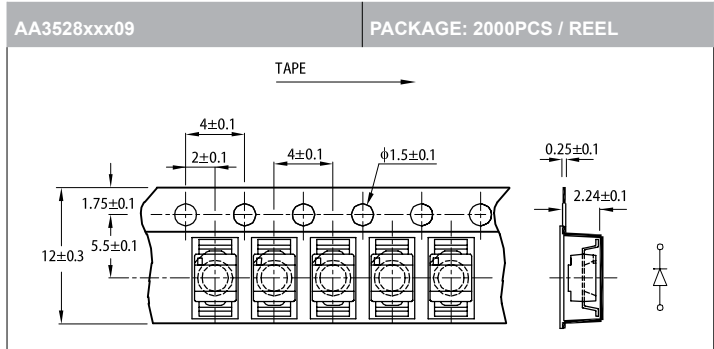
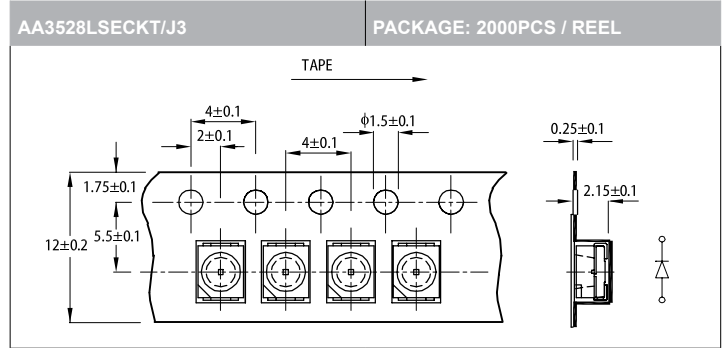
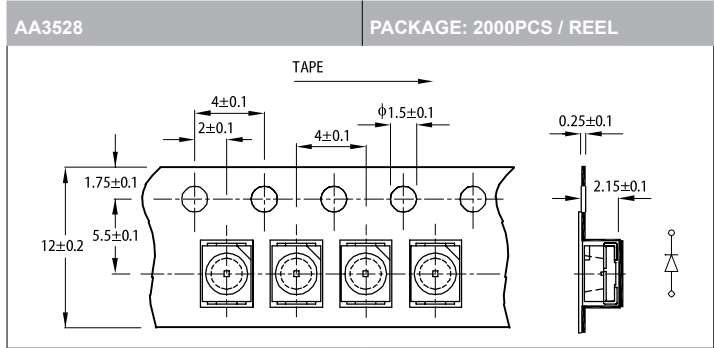
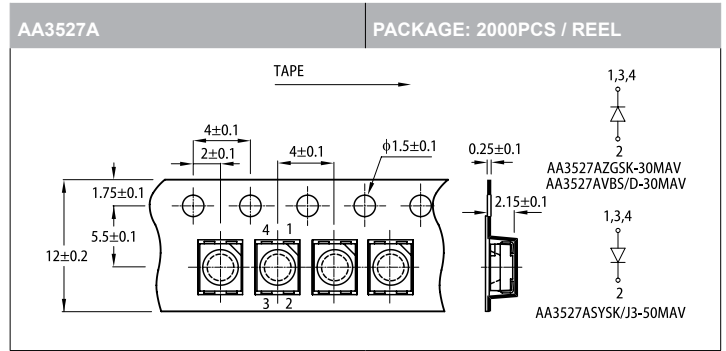
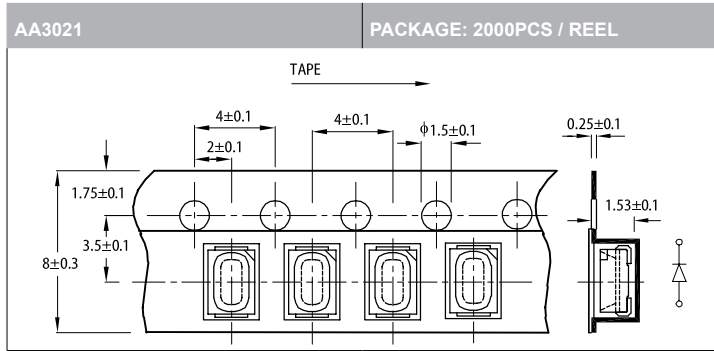

## SMD TAPE SPECIFICATIONS

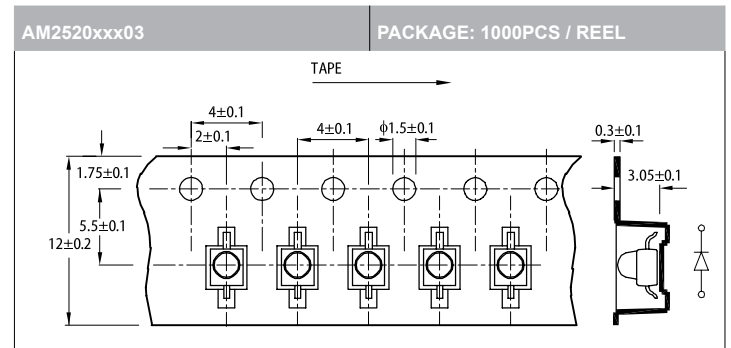
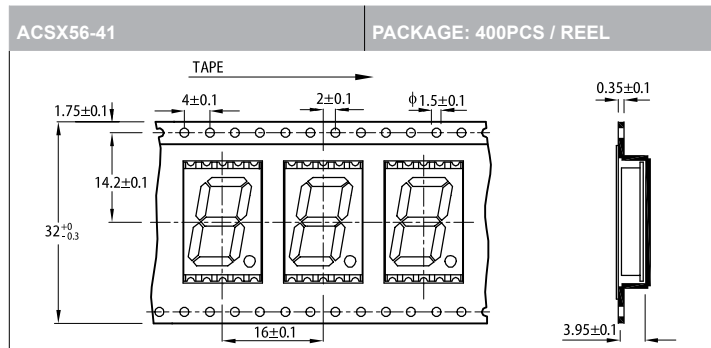
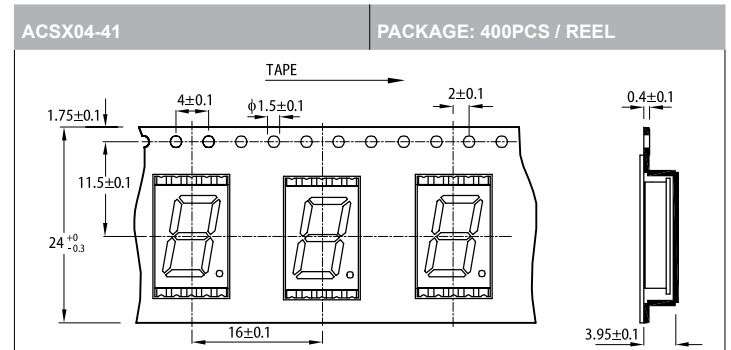
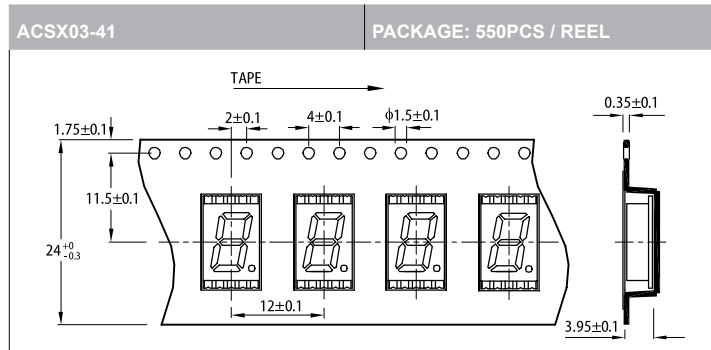
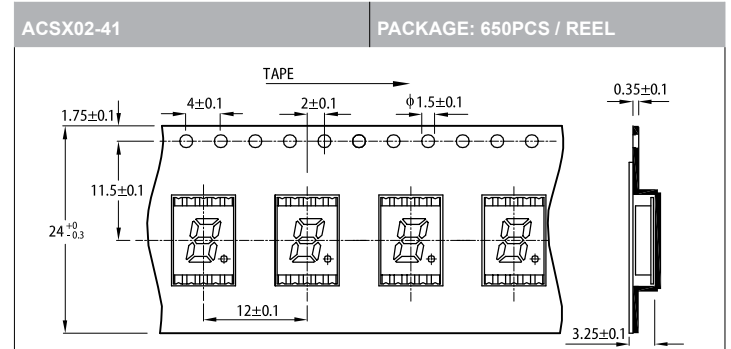
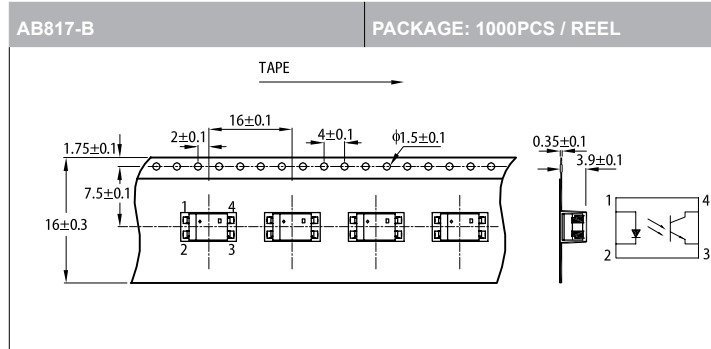
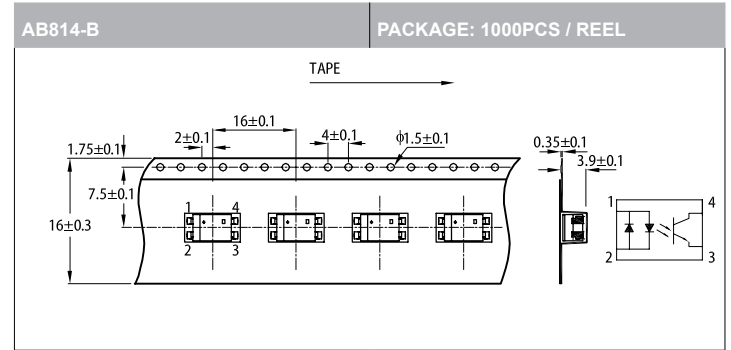
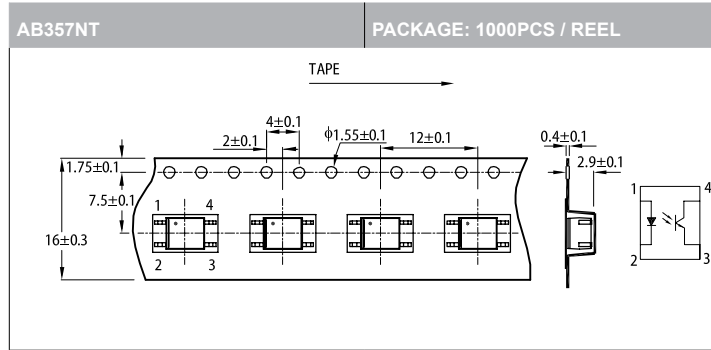
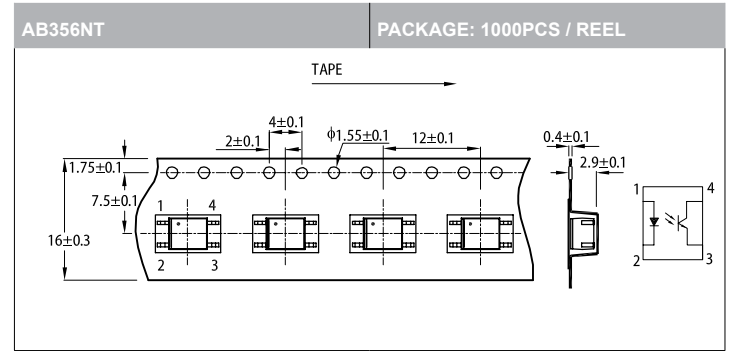
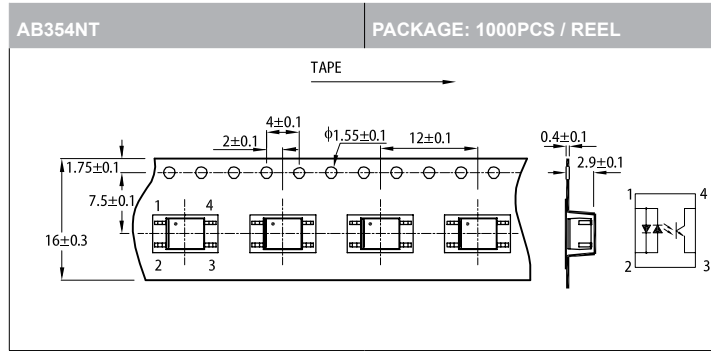

All dimensions are in millimeters

SMD TAPE SPECIFICATIONS

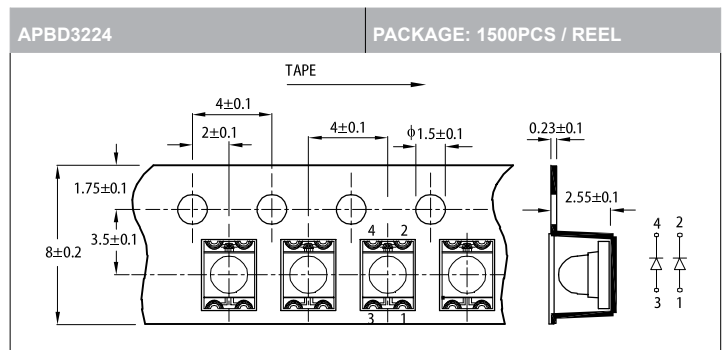
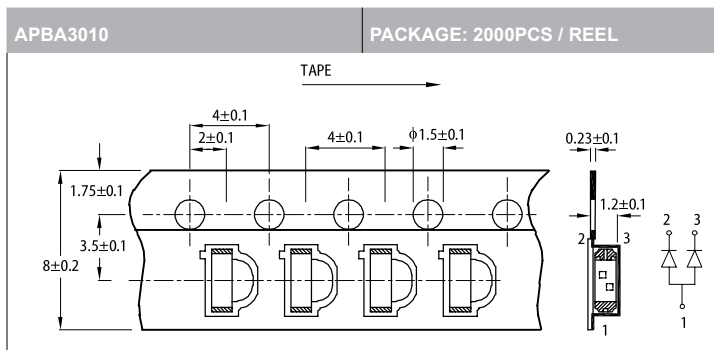
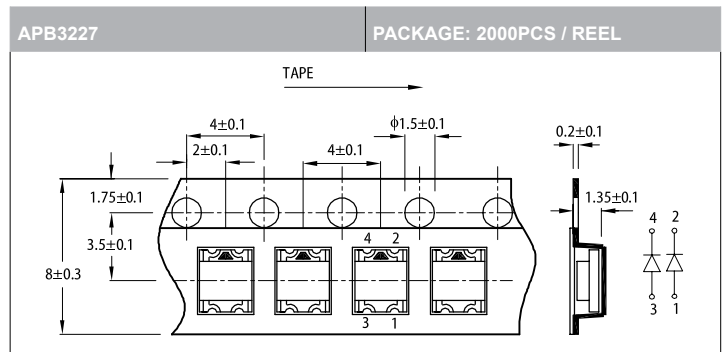
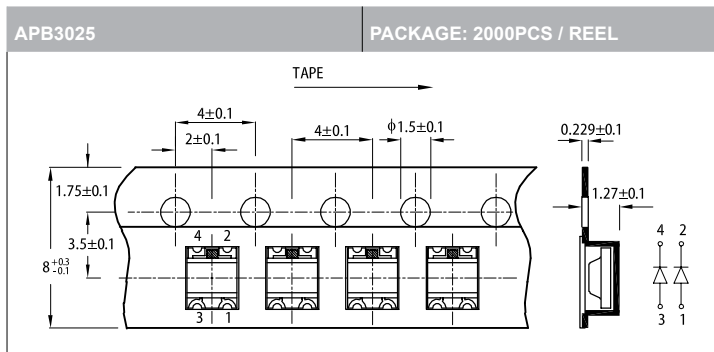
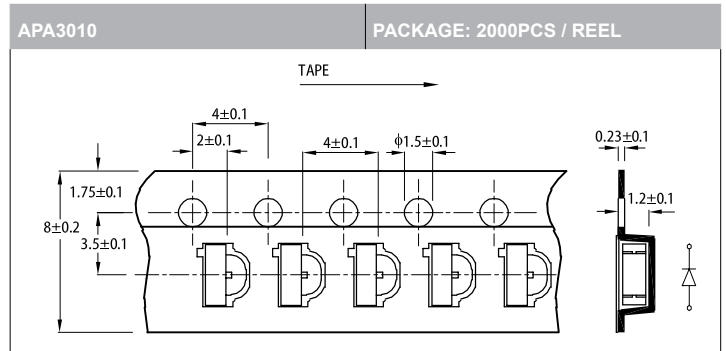
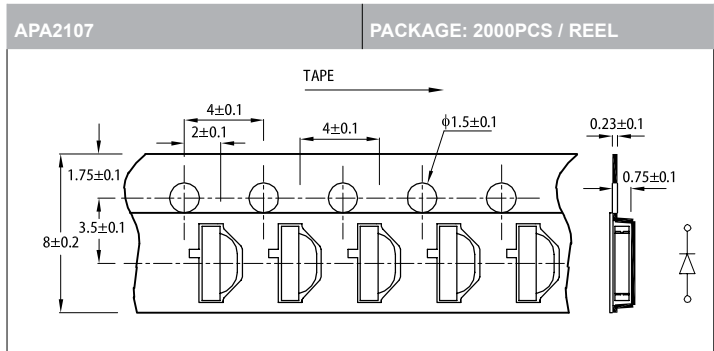
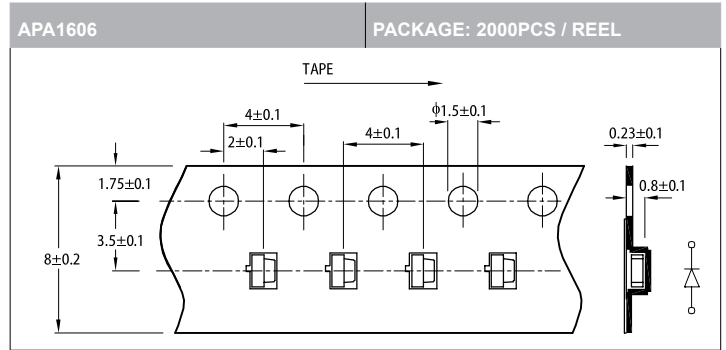
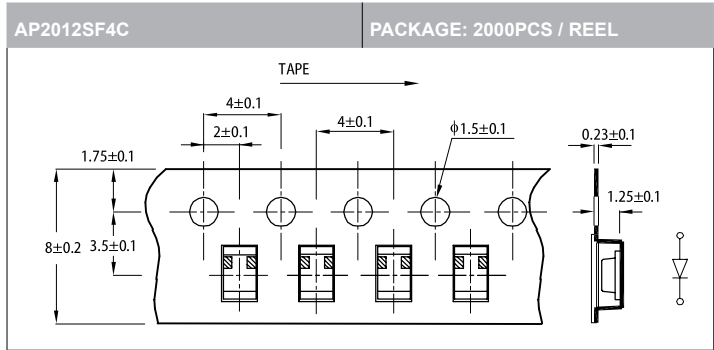
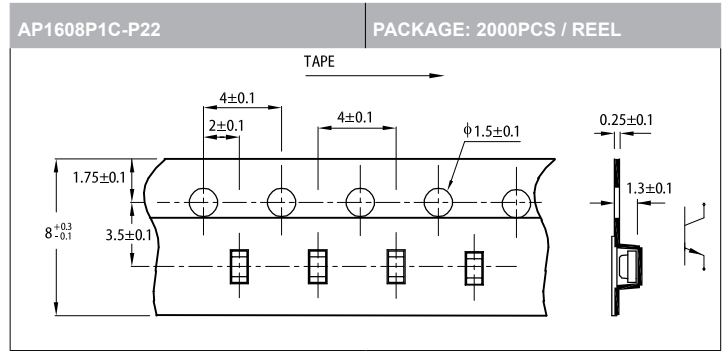
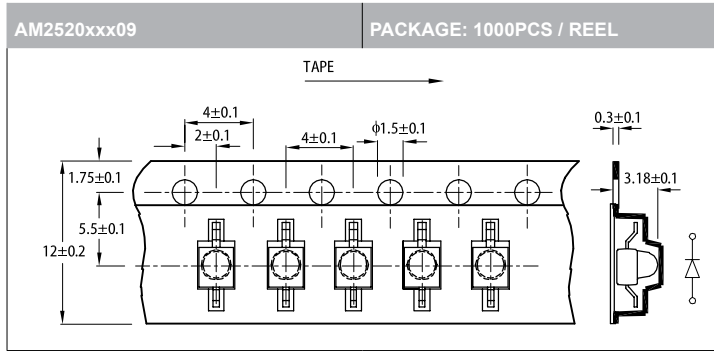

## SMD TAPE SPECIFICATIONS

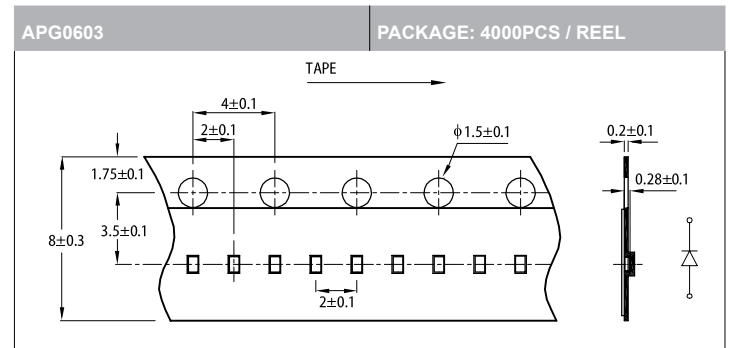
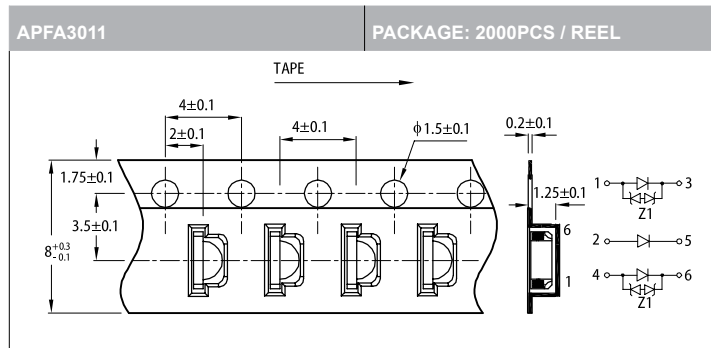
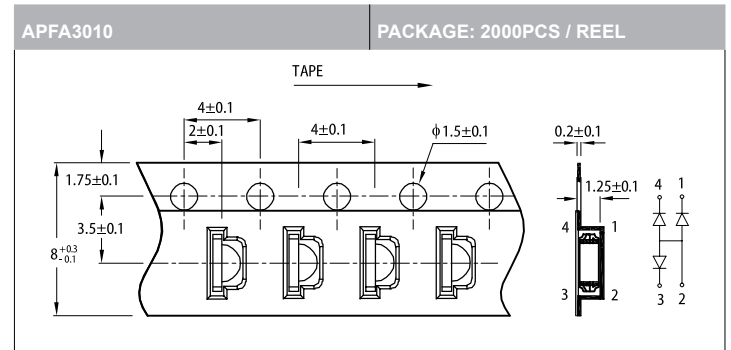
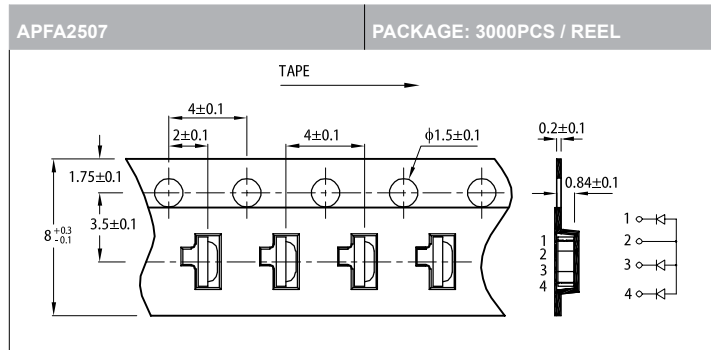
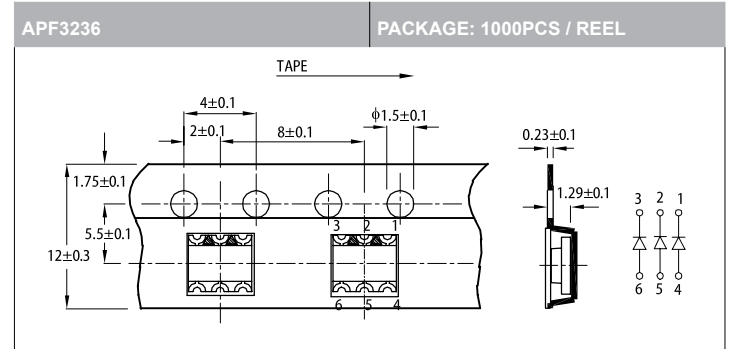
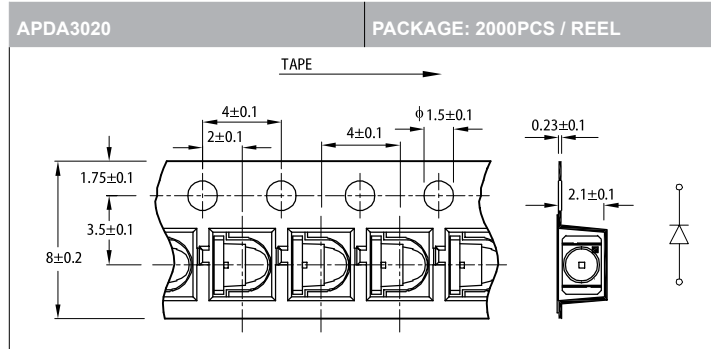
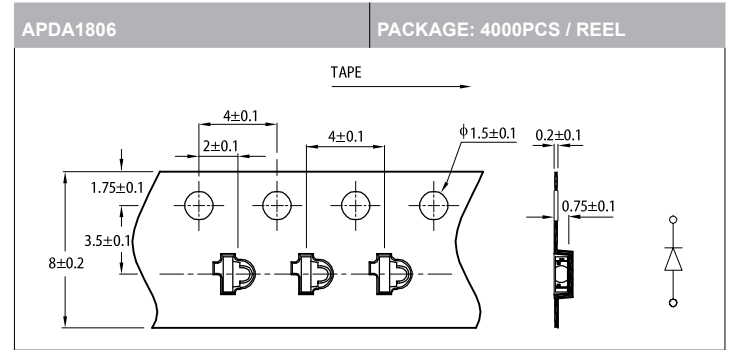
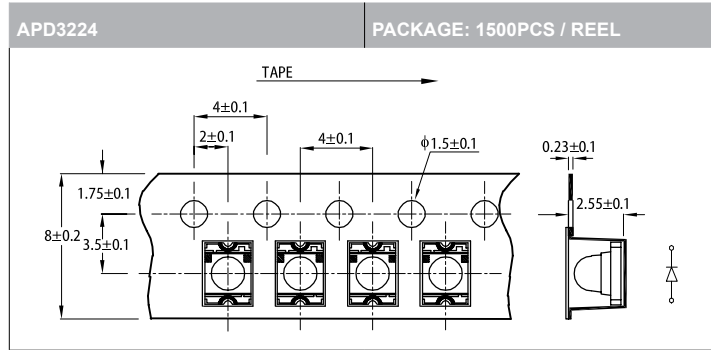
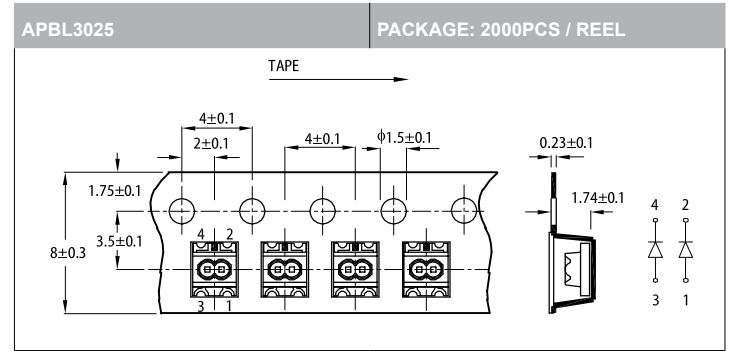
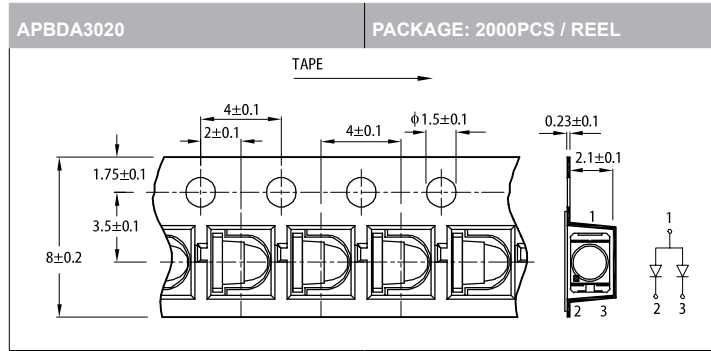

All dimensions are in millimeters

SMD TAPE SPECIFICATIONS

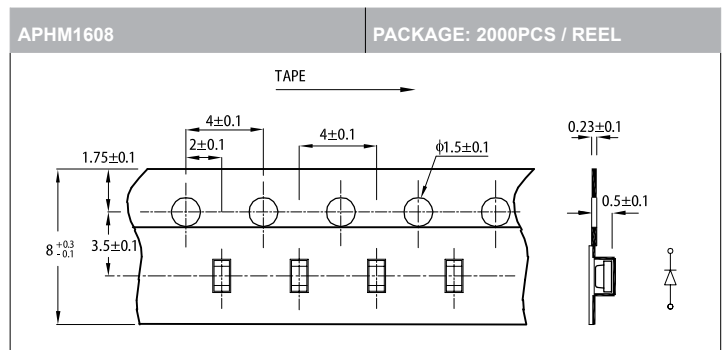
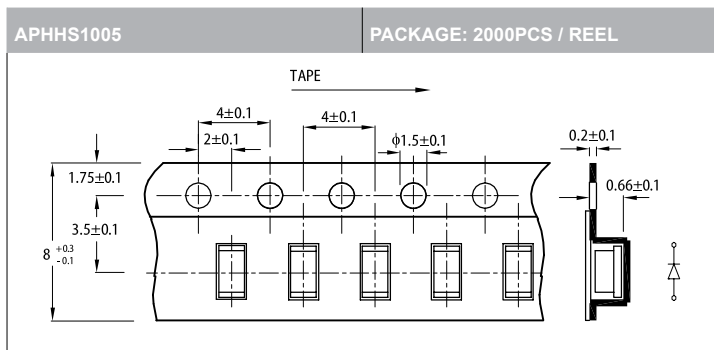
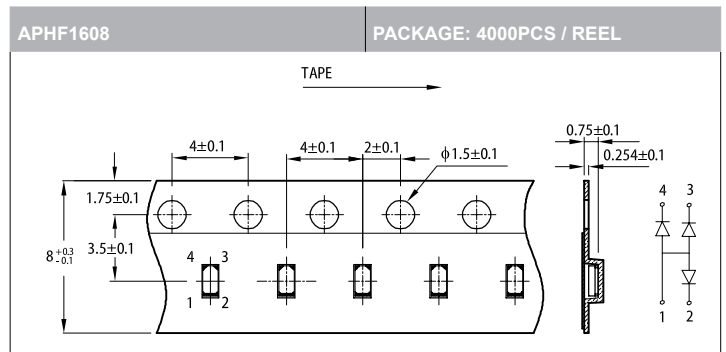
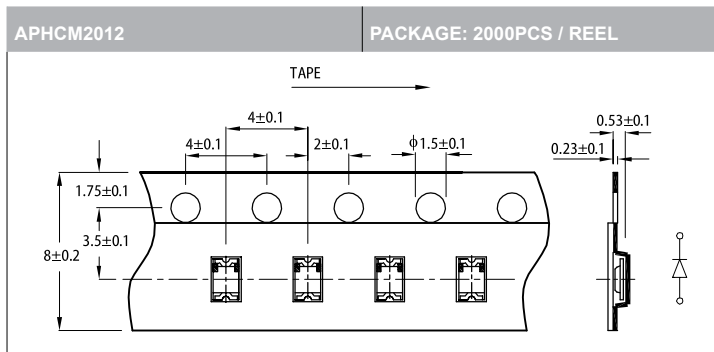
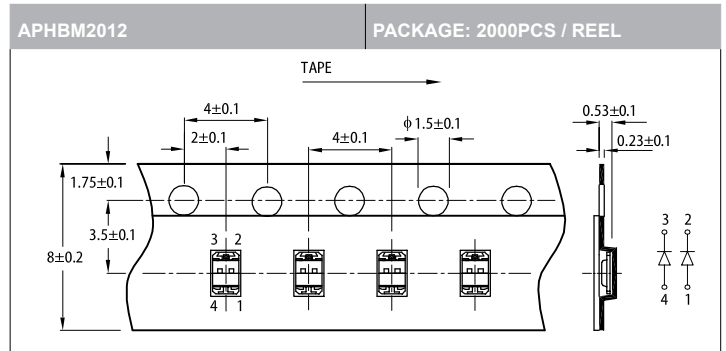
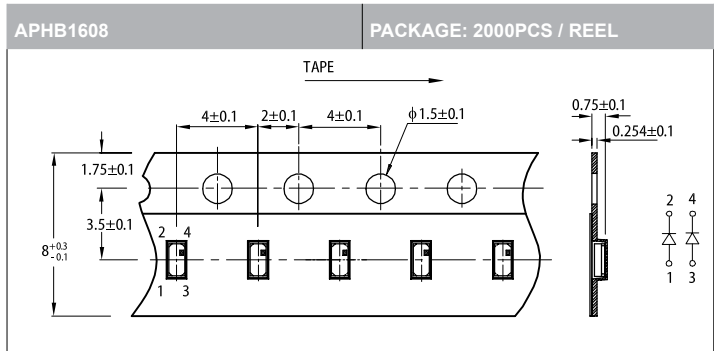
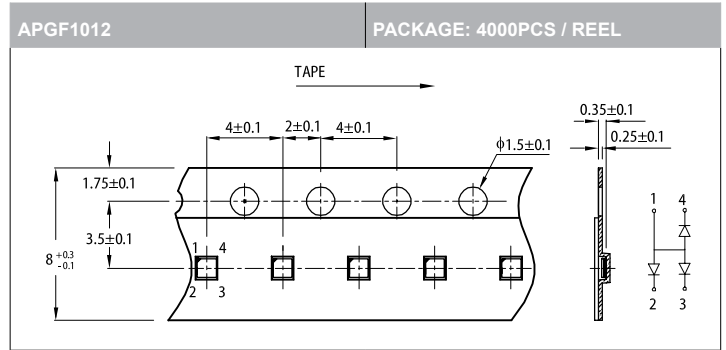
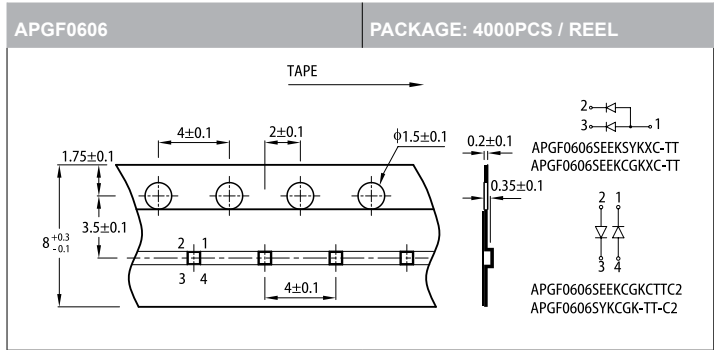
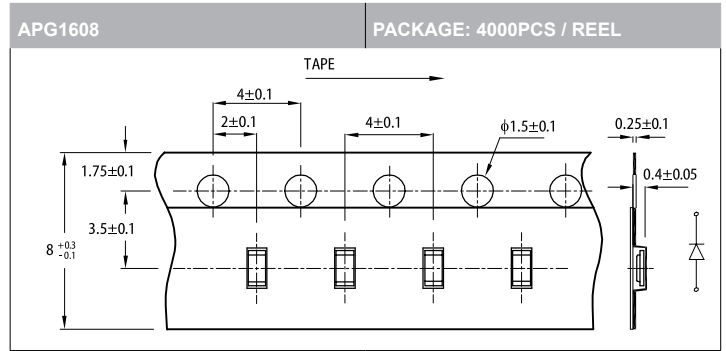
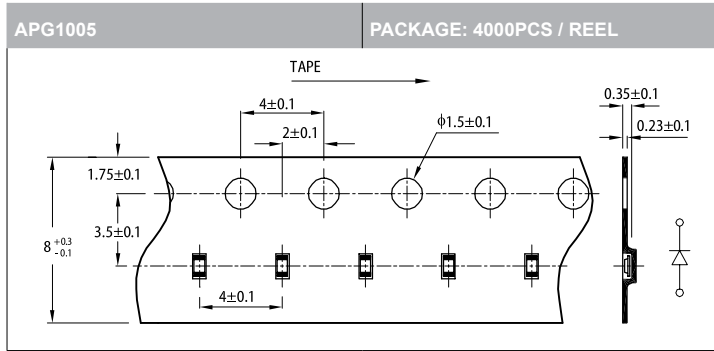

SMD TAPE SPECIFICATIONS

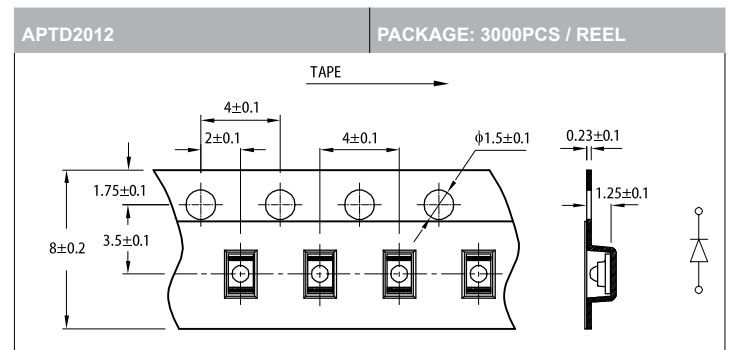
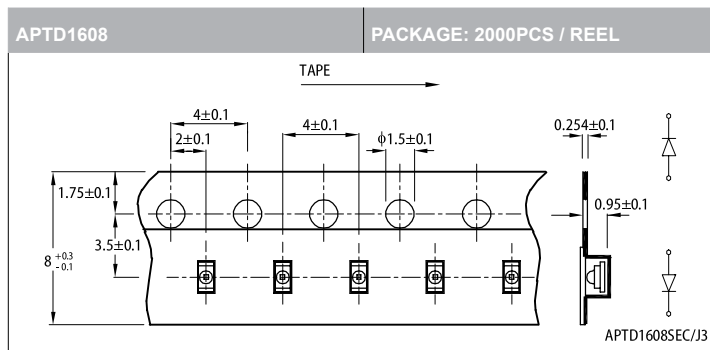
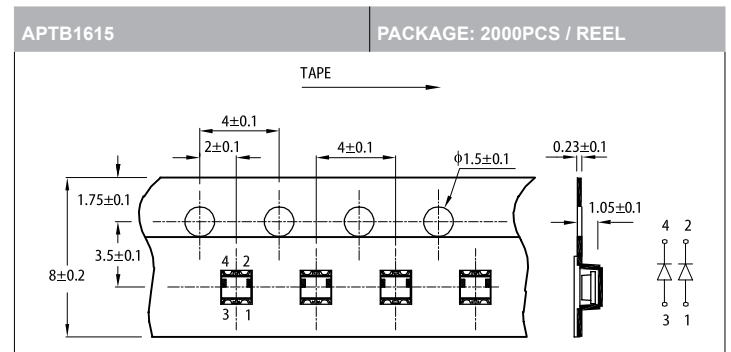
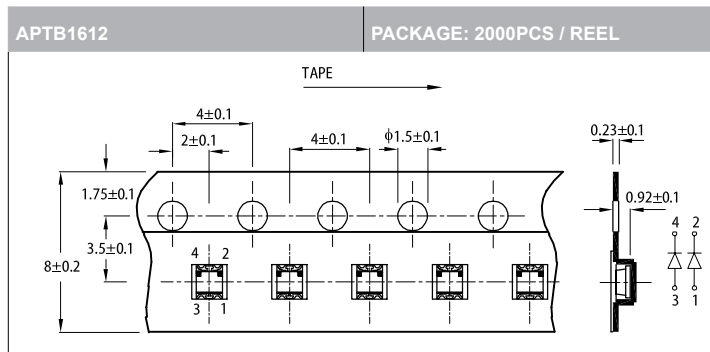
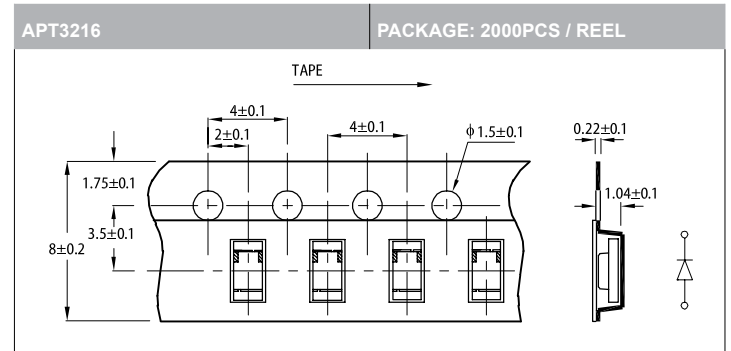
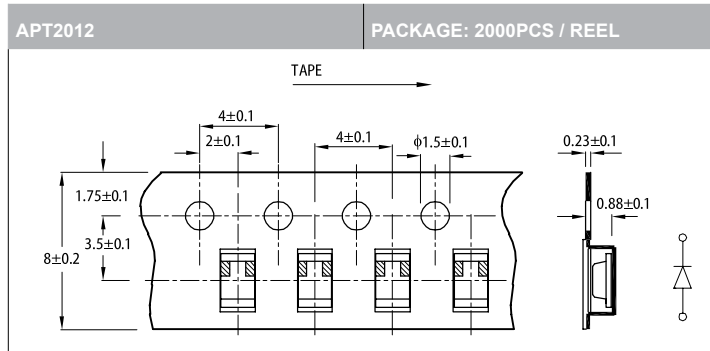
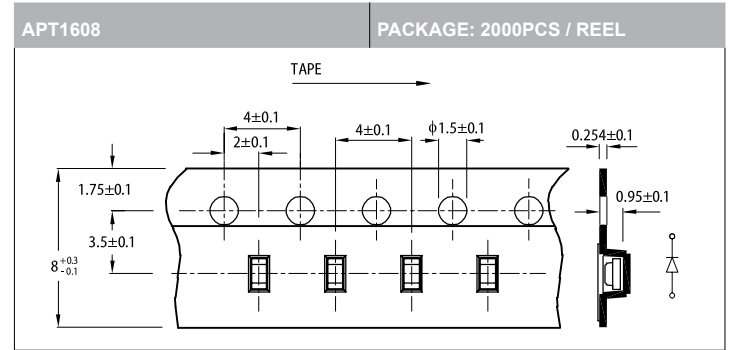
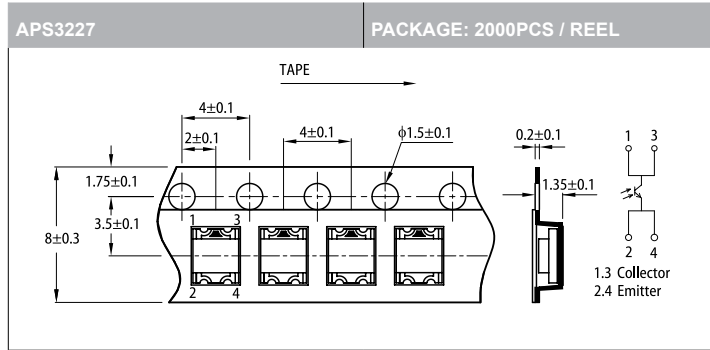
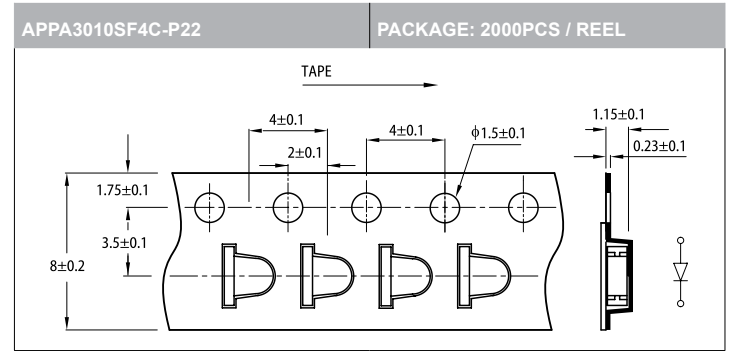
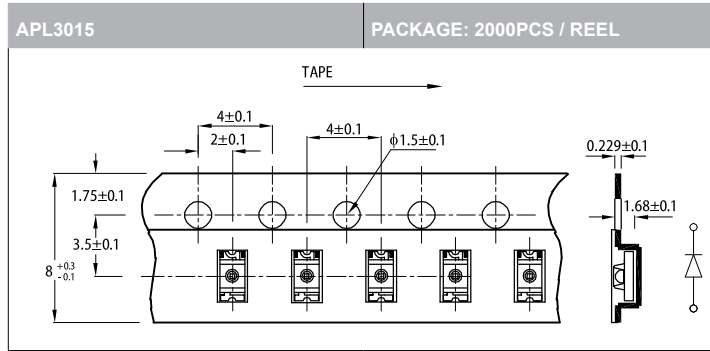

All dimensions are in millimeters



SMD TAPE SPECIFICATIONS

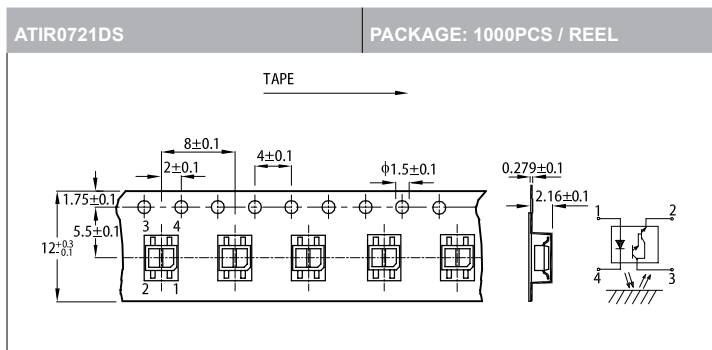
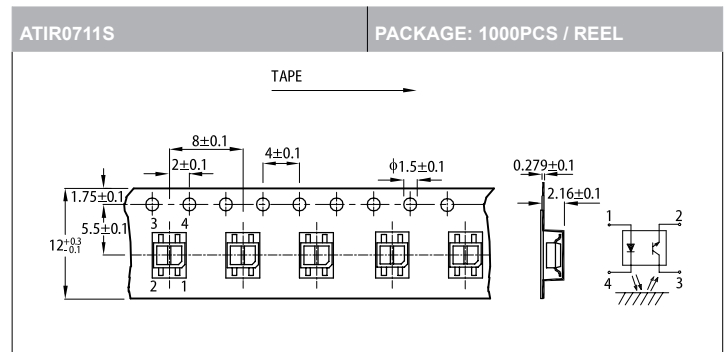
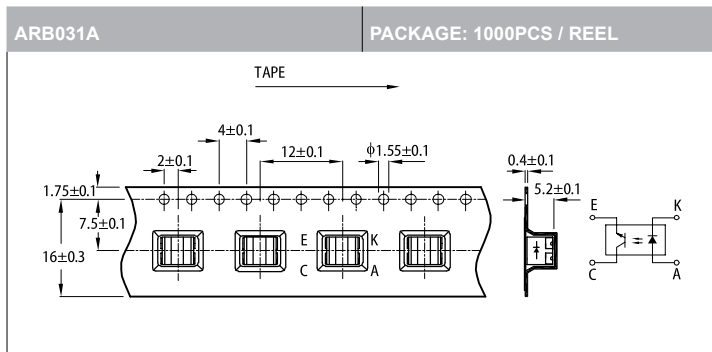
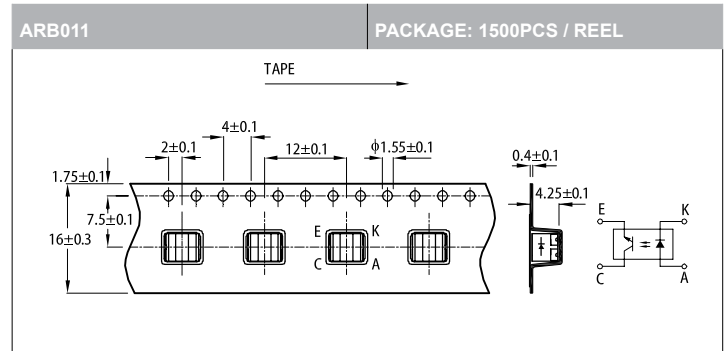
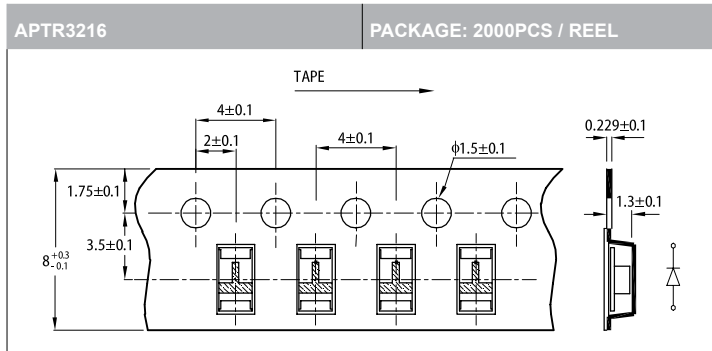
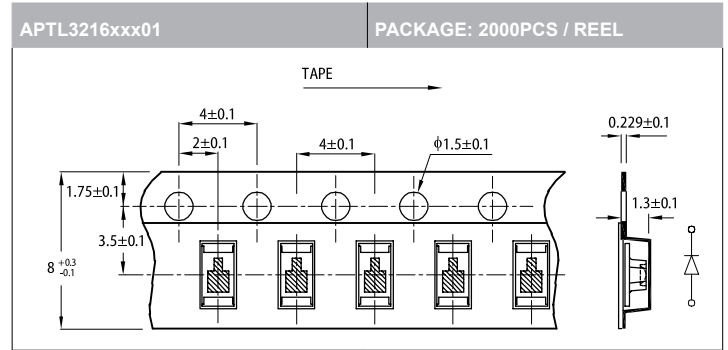
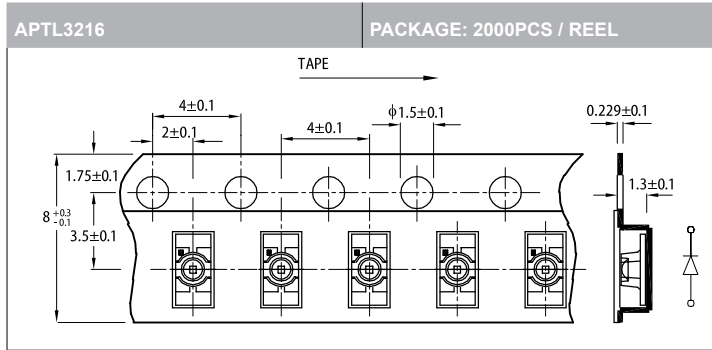
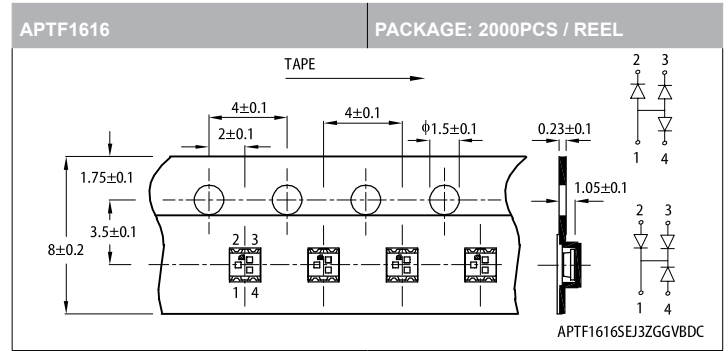
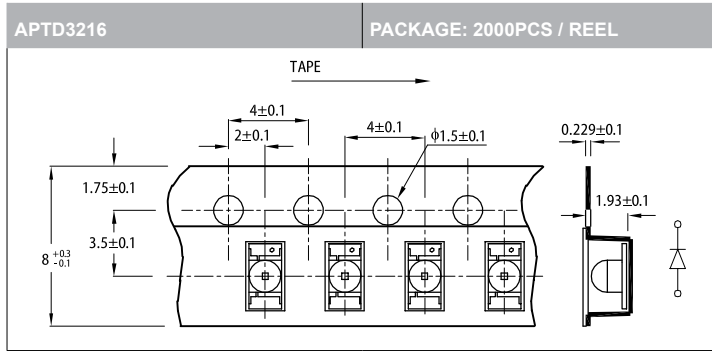

RECOMMENDED SOLDERING PATTERN

<p><b>AA1608</b></p>	<p><b>AA2810A</b></p>	<p><b>AA3021</b></p>
<p><b>AA3527A</b></p>	<p><b>AA3528</b></p>	<p><b>AA3528xxx09</b></p>
<p><b>AA4040</b></p>	<p><b>AAA3528</b></p>	<p><b>AAA3528xxx09</b></p>
<p><b>AAAF5050</b></p>	<p><b>AB354NT, AB356NT, AB357NT</b></p> <p>Tolerance: ± 0.15</p>	<p><b>AB814-B, AB817-B</b></p> <p>Tolerance: ± 0.15</p>
<p><b>ACSX02-41</b></p> <p>Tolerance: ± 0.15</p>	<p><b>ACSX03-41</b></p> <p>Tolerance: ± 0.15</p>	<p><b>ACSX04-41</b></p> <p>Tolerance: ± 0.15</p>

All dimensions are in millimeters. Tolerance is ± 0.1mm unless otherwise noted.

RECOMMENDED SOLDERING PATTERN

<p><b>ACSX56-41</b></p> <p>Tolerance: <math>\pm 0.15</math></p>	<p><b>AM2520xxx03</b></p>	<p><b>AM2520xxx09</b></p>
<p><b>AP1608, APHM1608, APT1608, APTD1608</b></p>	<p><b>AP2012, APT2012</b></p>	<p><b>APA1606</b></p>
<p><b>APA2107</b></p>	<p><b>APA3010, APBA3010</b></p>	<p><b>APB3025</b></p>
<p><b>APB3227</b></p>	<p><b>APBD3224</b></p>	<p><b>APBDA3020</b></p>
<p><b>APBL3025</b></p>	<p><b>APD3224</b></p>	<p><b>APDA1806</b></p>

RECOMMENDED SOLDERING PATTERN

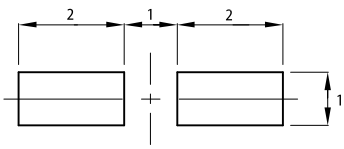
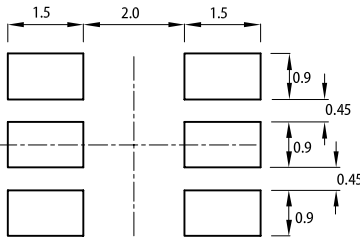
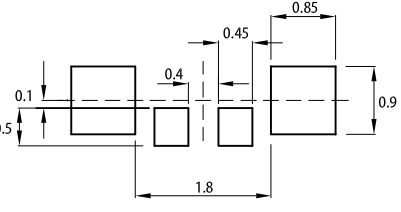
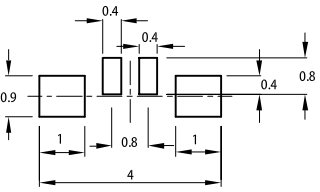
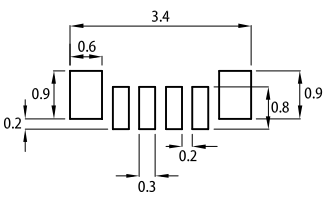
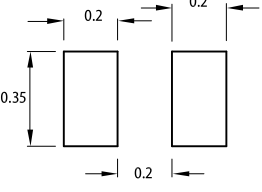
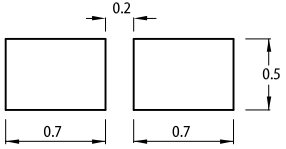
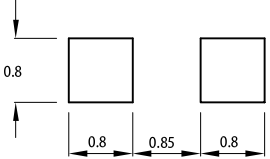
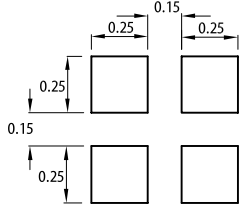
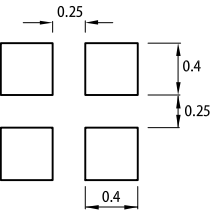
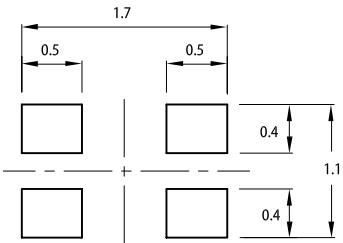
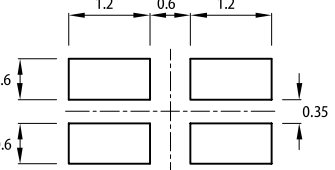
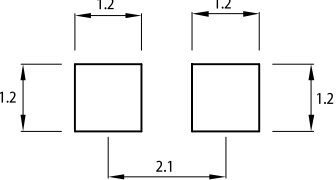
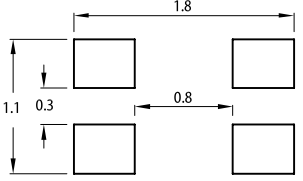
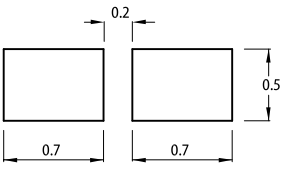
<p><b>APDA3020</b></p> 	<p><b>APF3236</b></p> 	<p><b>APFA2507</b></p> 
<p><b>APFA3010</b></p> 	<p><b>APFA3011</b></p> 	<p><b>APG0603</b></p>  <p>Mask open area ratio:80% Mask thickness:80~100um</p>
<p><b>APG1005</b></p>  <p>Mask open area ratio:80% Mask thickness:80~100um</p>	<p><b>APG1608</b></p>  <p>Mask open area ratio:80% Mask thickness:80~100um</p>	<p><b>APGF0606</b></p>  <p>Mask open area ratio:80% Mask thickness:80~100um</p>
<p><b>APGF1012</b></p>  <p>Mask open area ratio:80% Mask thickness:80~100um</p>	<p><b>APHB1608</b></p> 	<p><b>APHBM2012</b></p> 
<p><b>APHCM2012</b></p> 	<p><b>APHF1608</b></p> 	<p><b>APHHS1005</b></p> 

All dimensions are in millimeters. Tolerance is ± 0.1mm unless otherwise noted.

RECOMMENDED SOLDERING PATTERN

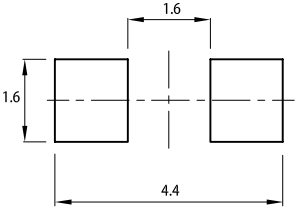
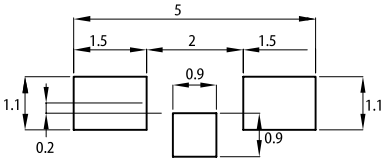
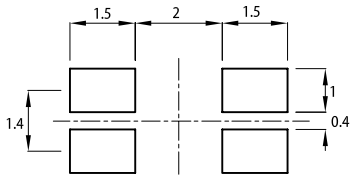
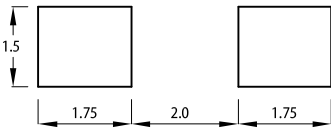
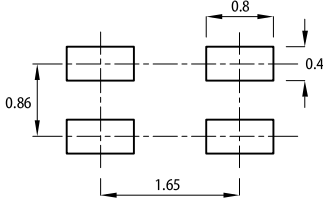
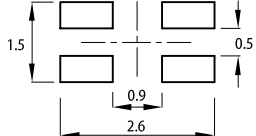
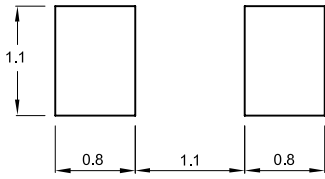
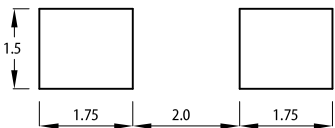
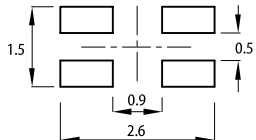
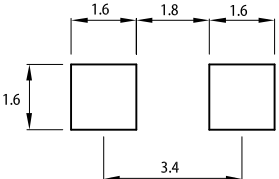
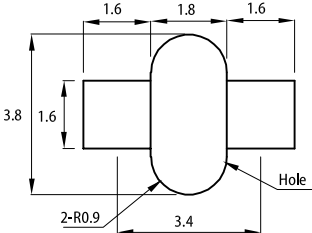
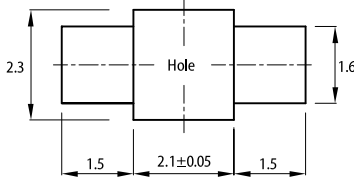
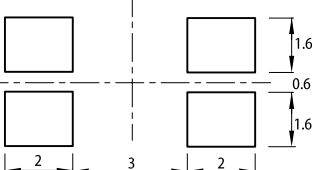
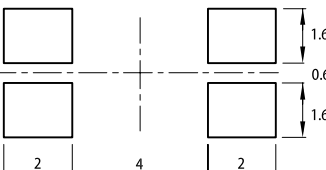
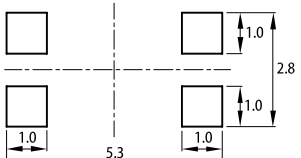
<p><b>APL3015</b></p> 	<p><b>APPA3010</b></p> 	<p><b>APS3227</b></p> 
<p><b>APT3216</b></p> 	<p><b>APTB1612</b></p> 	<p><b>APTB1615</b></p> 
<p><b>APTD2012</b></p> 	<p><b>APTD3216</b></p> 	<p><b>APTF1616</b></p> 
<p><b>APTL3216</b></p> 	<p><b>APTL3216xxx01</b></p> 	<p><b>APTR3216</b></p> 
<p><b>ARB011</b></p>  <p>Tolerance: ± 0.15</p>	<p><b>ARB031A</b></p>  <p>Tolerance: ± 0.15</p>	<p><b>ATIR0711S, ATIR0721DS</b></p> 

TECHNICAL DATA

Absolute maximum ratings (T <sub>A</sub> =25°C)		E Hi.Eff.Red (GaAsP/GaP)	I Hi.Eff.Red (GaAsP/GaP)	SR/J4 Super Bright Red (AlGaInP)	SURK Hyper Red (AlGaInP)	SURK/T Hyper Red (AlGaInP)	SUR/E Hyper Red (AlGaInP)	SEK/J3 Hyper Red (AlGaInP)	Unit
Reverse voltage	V <sub>R</sub>	5	5	5	5	5	5	5	V
Forward current	I <sub>F</sub>	30	30	30	30	30	30	30	mA
Forward current (Peak) 1/10 Duty Cycle, 0.1ms Pulse Width	I <sub>FP</sub>	160	160	150	185	150	200	150	mA
Power dissipation	P <sub>D</sub>	75	75	75	75	75	75	84	mW
<b>LED LAMPS:</b>									
Operating temperature	T <sub>A</sub>	-40~+85	-40~+85	-40~+85	-40~+85	-40~+85	-40~+85	-40~+85	°C
Storage temperature	T <sub>STG</sub>	-40~+85	-40~+85	-40~+85	-40~+85	-40~+85	-40~+85	-40~+85	°C
<b>LED DISPLAYS:</b>									
Operating temperature	T <sub>A</sub>	-40~+85	-40~+85	-40~+85	-40~+85	-40~+85	-40~+85	-40~+85	°C
Storage temperature	T <sub>STG</sub>	-40~+85	-40~+85	-40~+85	-40~+85	-40~+85	-40~+85	-40~+85	°C

Operating Characteristics		E Hi.Eff.Red (GaAsP/GaP)	I Hi.Eff.Red (GaAsP/GaP)	SR/J4 Super Bright Red (AlGaInP)	SURK Hyper Red (AlGaInP)	SURK/T Hyper Red (AlGaInP)	SUR/E Hyper Red (AlGaInP)	SEK/J3 Hyper Red (AlGaInP)	Unit
Forward voltage (typ.) I <sub>F</sub> =20mA	V <sub>F</sub>	2.0	2.0	2.1	1.95	2.0	1.9	2.2	V
I <sub>F</sub> =10mA		1.9	1.9	1.8	1.85	1.85	1.8	2.0	
I <sub>F</sub> =2mA		1.7	1.7	1.65	1.75	1.75	1.7	1.8	
Forward voltage (max.) I <sub>F</sub> =20mA	V <sub>F</sub>	2.5	2.5	2.5	2.5	2.5	2.5	2.8	V
I <sub>F</sub> =10mA		2.3	2.3	2.3	2.35	2.25	2.35	2.3	
I <sub>F</sub> =2mA		2.1	2.1	2.1	2.2	2.15	2.2	2.15	
Reverse current V <sub>R</sub> =5V	I <sub>R</sub>	10	10	10	10	10	10	10	µA
Peak Emission Wavelength I <sub>F</sub> =20mA, 10mA, 2mA	λ <sub>p</sub>	627	627	660	645	645	645	640	nm
Dominant Wavelength I <sub>F</sub> =20mA, 10mA, 2mA	λ <sub>D</sub>	617	617	640	630	630	630	625	nm
Spectral line half-width I <sub>F</sub> =20mA, 10mA, 2mA	Δλ <sub>1/2</sub>	45	45	20	28	20	25	20	nm
Capacitance V <sub>F</sub> =0V, f=1MHZ	C	15	15	45	35	35	45	27	pF

TECHNICAL DATA

Absolute maximum ratings (T <sub>A</sub> =25°C)		SE/J3 Hyper Red	SE/E Hyper Red	SEK/J4 Super Bright Orange	SEK Super Bright Orange	SEK/T Super Bright Orange	SE Super Bright Orange	G Green	Unit
		(AlGaInP)	(AlGaInP)	(AlGaInP)	(AlGaInP)	(AlGaInP)	(AlGaInP)	(GaP)	
Reverse voltage	V <sub>R</sub>	5	5	5	5	5	5	5	V
Forward current	I <sub>F</sub>	30	30	30	30	30	30	25	mA
Forward current (Peak) 1/10 Duty Cycle, 0.1ms Pulse Width	I <sub>FP</sub>	150	195	150	195	150	195	140	mA
Power dissipation	P <sub>D</sub>	84	75	84	75	75	75	62.5	mW
<b>LED LAMPS:</b>									
Operating temperature	T <sub>A</sub>	-40~+85	-40~+85	-40~+85	-40~+85	-40~+85	-40~+85	-40~+85	°C
Storage temperature	T <sub>STG</sub>	-40~+85	-40~+85	-40~+85	-40~+85	-40~+85	-40~+85	-40~+85	°C
<b>LED DISPLAYS:</b>									
Operating temperature	T <sub>A</sub>	-40~+85	-40~+85	-40~+85	-40~+85	-40~+85	-40~+85	-40~+85	°C
Storage temperature	T <sub>STG</sub>	-40~+85	-40~+85	-40~+85	-40~+85	-40~+85	-40~+85	-40~+85	°C

Operating Characteristics		SE/J3 Hyper Red	SE/E Hyper Red	SEK/J4 Super Bright Orange	SEK Super Bright Orange	SEK/T Super Bright Orange	SE Super Bright Orange	G Green	Unit
		(AlGaInP)	(AlGaInP)	(AlGaInP)	(AlGaInP)	(AlGaInP)	(AlGaInP)	(GaP)	
Forward voltage (typ.) I <sub>F</sub> =20mA	V <sub>F</sub>	2.2	2.0	2.2	2.1	2.05	2.0	2.2	V
I <sub>F</sub> =10mA		2.0	1.9	2.0	2.0	1.95	1.9	2.0	
I <sub>F</sub> =2mA		1.8	1.8	1.8	1.85	1.8	1.8	1.9	
Forward voltage (max.) I <sub>F</sub> =20mA	V <sub>F</sub>	2.8	2.5	2.8	2.5	2.5	2.5	2.5	V
I <sub>F</sub> =10mA		2.3	2.3	2.4	2.35	2.3	2.4	2.4	
I <sub>F</sub> =2mA		2.15	2.1	2.2	2.2	2.2	2.2	2.25	
Reverse current V <sub>R</sub> =5V	I <sub>R</sub>	10	10	10	10	10	10	10	µA
Peak Emission Wavelength I <sub>F</sub> =20mA, 10mA, 2mA	λ <sub>P</sub>	640	630	611	610	610	610	565	nm
Dominant Wavelength I <sub>F</sub> =20mA, 10mA, 2mA	λ <sub>D</sub>	625	621	605	605	601	605	568	nm
Spectral line half-width I <sub>F</sub> =20mA, 10mA, 2mA	Δλ <sub>1/2</sub>	25	20	17	29	17	29	30	nm
Capacitance V <sub>F</sub> =0V, f=1MHZ	C	27	25	27	15	15	30	15	pF

TECHNICAL DATA

Absolute maximum ratings (T <sub>A</sub> =25°C)		CGK/TT Green	CGK Green	CGK/T Green	ZGK Green	ZG Green	ZG/G Green	Y Yellow	Unit
		(AlGaInP)	(AlGaInP)	(AlGaInP)	(InGaN)	(InGaN)	(InGaN)	(GaAsP/GaP)	
Reverse voltage	V <sub>R</sub>	5	5	5	5	5	5	5	V
Forward current	I <sub>F</sub>	25	30	30	25	25	30	30	mA
Forward current (Peak) 1/10 Duty Cycle, 0.1ms Pulse Width	I <sub>FP</sub>	120	150	150	150	150	100	140	mA
Power dissipation	P <sub>D</sub>	60	75	78	102.5	102.5	120	75	mW
<b>LED LAMPS:</b>									
Operating temperature	T <sub>A</sub>	-40~+85	-40~+85	-40~+85	-40~+85	-40~+85	-40~+85	-40~+85	°C
Storage temperature	T <sub>STG</sub>	-40~+85	-40~+85	-40~+85	-40~+85	-40~+85	-40~+85	-40~+85	°C
<b>LED DISPLAYS:</b>									
Operating temperature	T <sub>A</sub>	-40~+85	-40~+85	-40~+85	-40~+85	-40~+85	-40~+85	-40~+85	°C
Storage temperature	T <sub>STG</sub>	-40~+85	-40~+85	-40~+85	-40~+85	-40~+85	-40~+85	-40~+85	°C

Operating Characteristics		CGK/TT Green	CGK Green	CGK/T Green	ZGK Green	ZG Green	ZG/G Green	Y Yellow	Unit
		(AlGaInP)	(AlGaInP)	(AlGaInP)	(InGaN)	(InGaN)	(InGaN)	(GaAsP/GaP)	
Forward voltage (typ.) I <sub>F</sub> =20mA	V <sub>F</sub>	2.0	2.1	2.1	3.3	3.3	3.2	2.1	V
I <sub>F</sub> =10mA		1.97	2.0	1.95	3.0	3.0	3.05	1.95	
I <sub>F</sub> =2mA		1.87	1.9	1.8	2.65	2.65	2.8	1.85	
Forward voltage (max.) I <sub>F</sub> =20mA	V <sub>F</sub>	2.4	2.5	2.6	4.1	4.1	4.0	2.5	V
I <sub>F</sub> =10mA		2.35	2.45	2.4	3.4	3.4	3.4	2.4	
I <sub>F</sub> =2mA		2.2	2.3	2.3	3.1	3.1	3.1	2.2	
Reverse current V <sub>R</sub> =5V	I <sub>R</sub>	10	10	10	50	50	50	10	µA
Peak Emission Wavelength I <sub>F</sub> =20mA, 10mA, 2mA	λ <sub>P</sub>	572	574	574	515	515	520	590	nm
Dominant Wavelength I <sub>F</sub> =20mA, 10mA, 2mA	λ <sub>D</sub>	571	570	570	525	525	525	588	nm
Spectral line half-width I <sub>F</sub> =20mA, 10mA, 2mA	Δλ <sub>1/2</sub>	20	20	15	35	30	35	35	nm
Capacitance V <sub>F</sub> =0V, f=1MHZ	C	15	15	15	45	45	100	20	pF



TECHNICAL DATA

Absolute maximum ratings (T <sub>A</sub> =25°C)		SYK Super Bright Yellow	SYK/T Super Bright Yellow	SY Super Bright Yellow	SY/J3 Super Bright Yellow	SYK/J3 Super Bright Yellow	QB/D Blue	VB/D Blue	Unit
		(AlGaInP)	(AlGaInP)	(AlGaInP)	(AlGaInP)	(AlGaInP)	(InGaN)	(InGaN)	
Reverse voltage	V <sub>R</sub>	5	5	5	5	5	5	5	V
Forward current	I <sub>F</sub>	30	30	30	30	30	30	30	mA
Forward current (Peak) 1/10 Duty Cycle, 0.1ms Pulse Width	I <sub>FP</sub>	175	150	150	140	140	150	100	mA
Power dissipation	P <sub>D</sub>	75	75	75	75	75	120	120	mW
<b>LED LAMPS:</b>									
Operating temperature	T <sub>A</sub>	-40~+85	-40~+85	-40~+85	-40~+85	-40~+85	-40~+85	-40~+85	°C
Storage temperature	T <sub>STG</sub>	-40~+85	-40~+85	-40~+85	-40~+85	-40~+85	-40~+85	-40~+85	°C
<b>LED DISPLAYS:</b>									
Operating temperature	T <sub>A</sub>	-40~+85	-40~+85	-40~+85	-40~+85	-40~+85	-40~+85	-40~+85	°C
Storage temperature	T <sub>STG</sub>	-40~+85	-40~+85	-40~+85	-40~+85	-40~+85	-40~+85	-40~+85	°C

Operating Characteristics		SYK Super Bright Yellow	SYK/T Super Bright Yellow	SY Super Bright Yellow	SY/J3 Super Bright Yellow	SYK/J3 Super Bright Yellow	QB/D Blue	VB/D Blue	Unit
		(AlGaInP)	(AlGaInP)	(AlGaInP)	(AlGaInP)	(AlGaInP)	(InGaN)	(InGaN)	
Forward voltage (typ.) I <sub>F</sub> =20mA	V <sub>F</sub>	2.0	2.05	2.0	2.0	2.0	3.3	3.3	V
I <sub>F</sub> =10mA		1.95	1.95	1.95	1.95	1.95	3.0	3.0	
I <sub>F</sub> =2mA		1.85	1.8	1.8	1.85	1.85	2.65	2.65	
Forward voltage (max.) I <sub>F</sub> =20mA	V <sub>F</sub>	2.5	2.5	2.5	2.5	2.5	4.0	4.0	V
I <sub>F</sub> =10mA		2.35	2.3	2.35	2.4	2.4	3.5	3.4	
I <sub>F</sub> =2mA		2.2	2.2	2.2	2.2	2.2	3.1	3.1	
Reverse current V <sub>R</sub> =5V	I <sub>R</sub>	10	10	10	10	10	50	50	µA
Peak Emission Wavelength I <sub>F</sub> =20mA, 10mA, 2mA	λ <sub>P</sub>	590	590	590	590	590	460	465	nm
Dominant Wavelength I <sub>F</sub> =20mA, 10mA, 2mA	λ <sub>D</sub>	590	590	590	590	590	465	470	nm
Spectral line half-width I <sub>F</sub> =20mA, 10mA, 2mA	Δλ <sub>1/2</sub>	20	15	28	20	20	25	22	nm
Capacitance V <sub>F</sub> =0V, f=1MHZ	C	20	25	25	45	45	100	100	pF

TECHNICAL DATA FOR INFRARED

Absolute maximum ratings (T <sub>A</sub> =25°C)		F3 (GaAs)	SF4 (GaAlAs)	SF6 (GaAlAs)	SF7 (GaAlAs)	Unit
Reverse voltage	V <sub>R</sub>	5	5	5	5	V
Forward current	I <sub>F</sub>	50	50	50	50	mA
Forward current (Peak) 1/100 Duty Cycle, 10μs Pulse Width	I <sub>FP</sub>	1.2	1.2	1	1	mA
Power dissipation	P <sub>D</sub>	90	85	85	95	mW
<b>LED LAMPS:</b>						
Operating temperature	T <sub>A</sub>	-40~+85	-40~+85	-40~+85	-40~+85	°C
Storage temperature	T <sub>STG</sub>	-40~+85	-40~+85	-40~+85	-40~+85	°C
<b>LED DISPLAYS:</b>						
Operating temperature	T <sub>A</sub>	-40~+85	-40~+85	-40~+85	-40~+85	°C
Storage temperature	T <sub>STG</sub>	-40~+85	-40~+85	-40~+85	-40~+85	°C

Operating Characteristics		F3 (GaAs)	SF4 (GaAlAs)	SF6 (GaAlAs)	SF7 (GaAlAs)	Unit
Forward voltage (typ.) I <sub>F</sub> =20mA	V <sub>F</sub>	1.2	1.3	1.35	1.4	V
Forward voltage (max.) I <sub>F</sub> =20mA	V <sub>F</sub>	1.6	1.6	1.6	1.6	V
Reverse current V <sub>R</sub> =5V	I <sub>R</sub>	10	10	10	10	μA
Peak Emission Wavelength I <sub>F</sub> =20mA	λ <sub>p</sub>	940	880	860	850	nm
Spectral line half-width I <sub>F</sub> =20mA	Δλ1/2	50	50	50	50	nm
Capacitance V <sub>F</sub> =0V,f=1MHZ	C	90	90	30	30	pF

TECHNICAL DATA

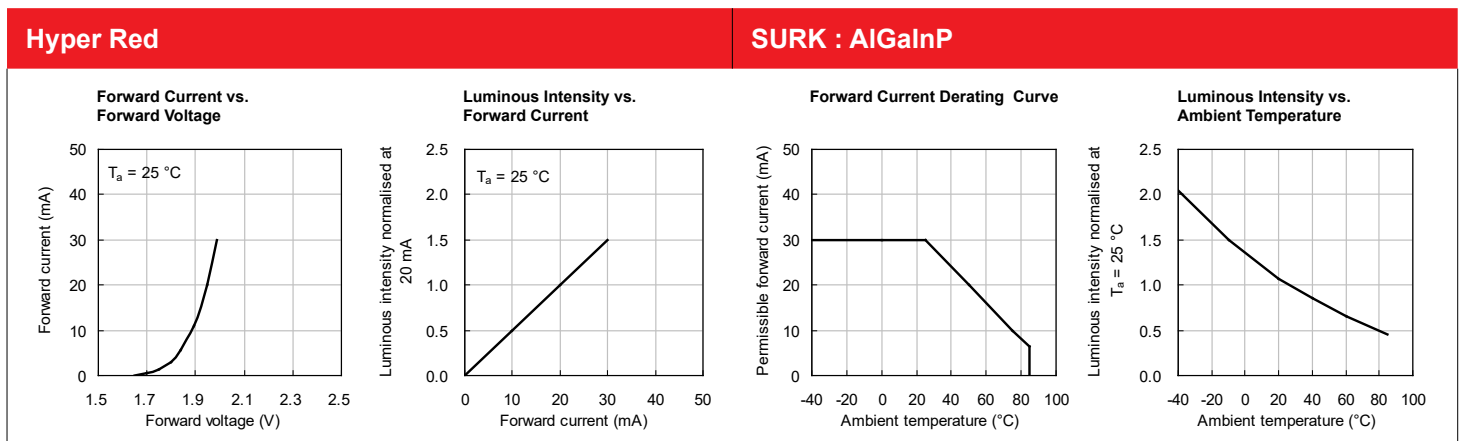
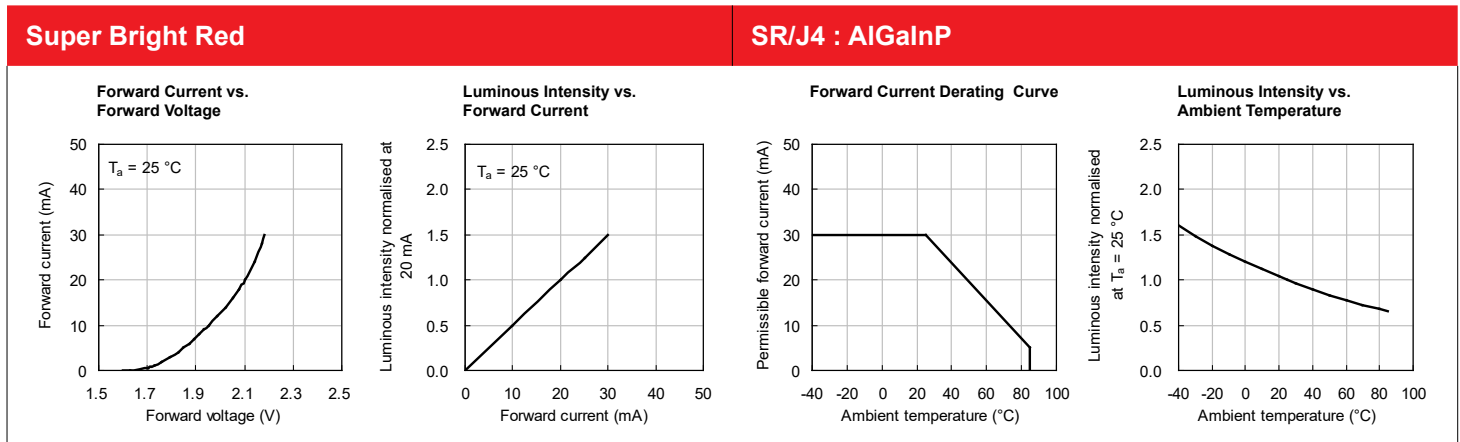
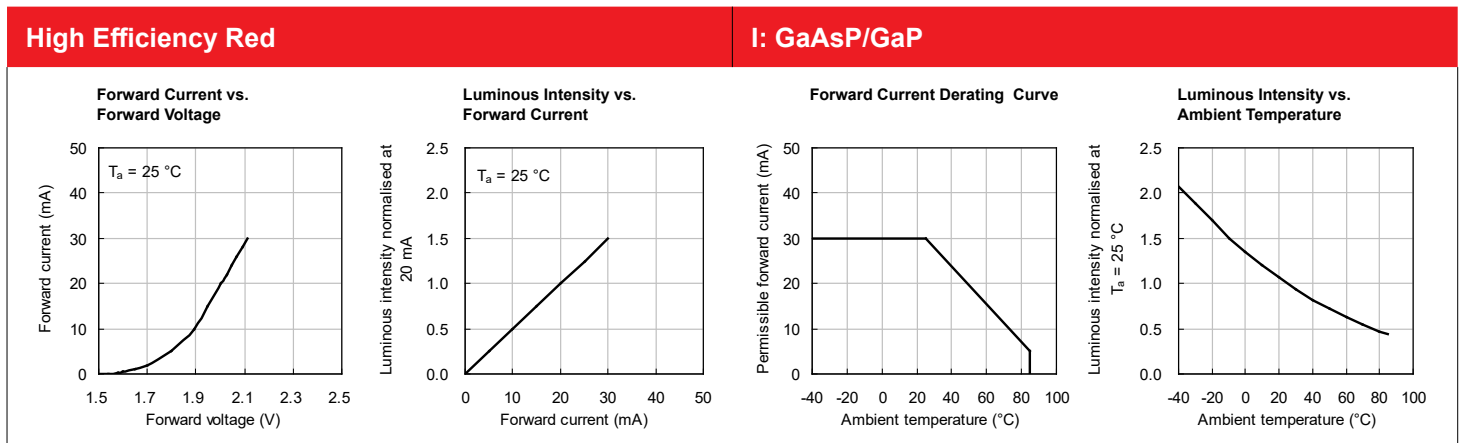
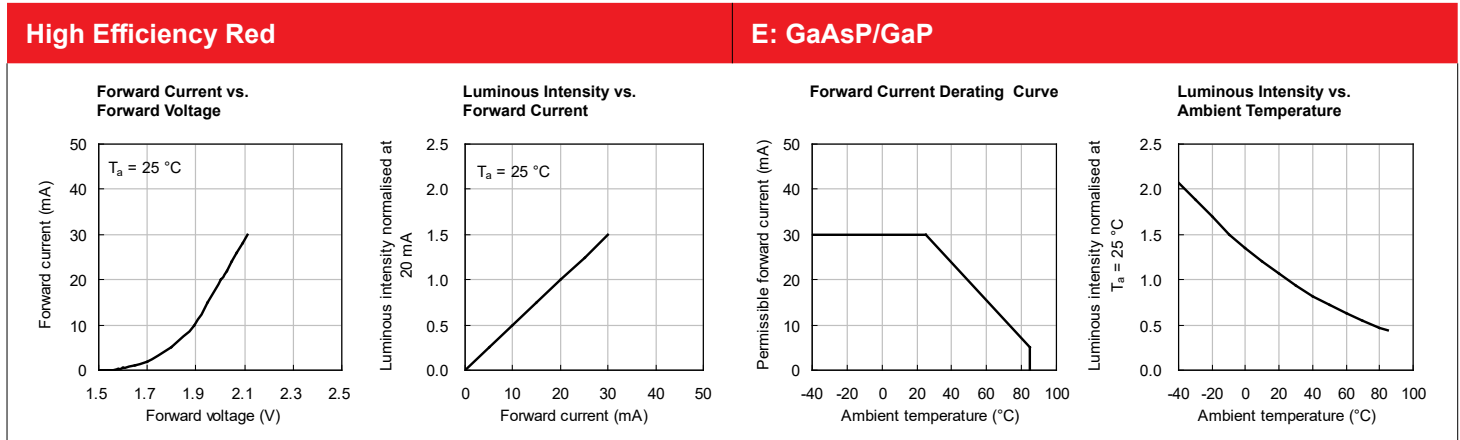

TECHNICAL DATA

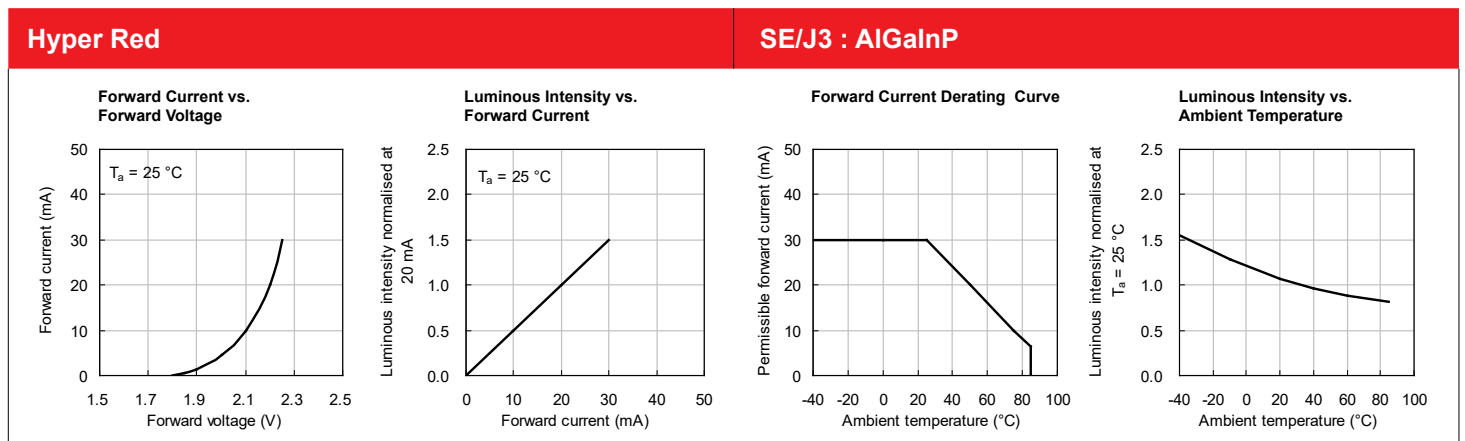
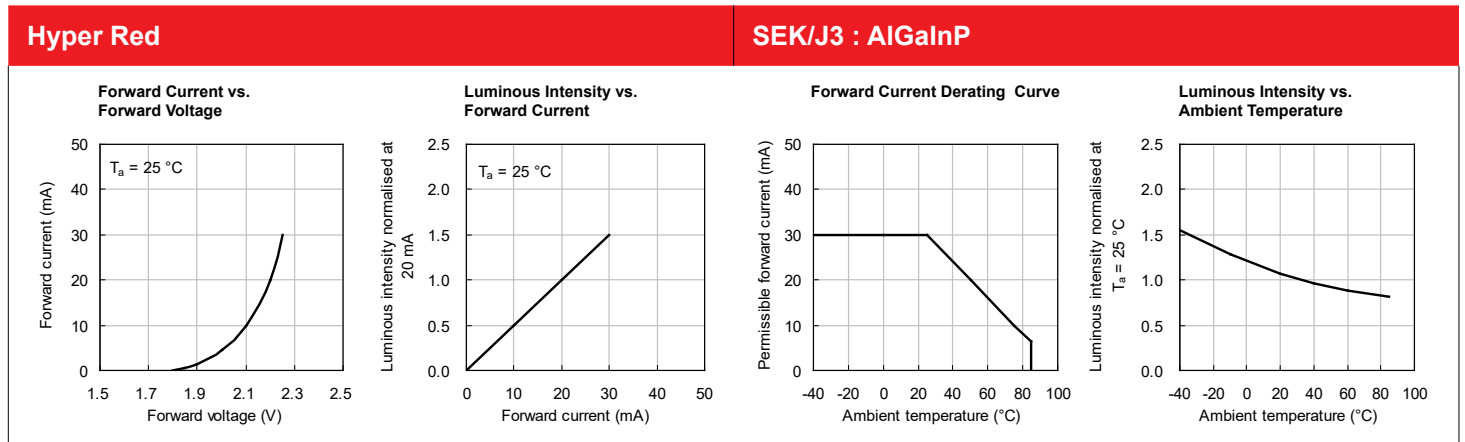
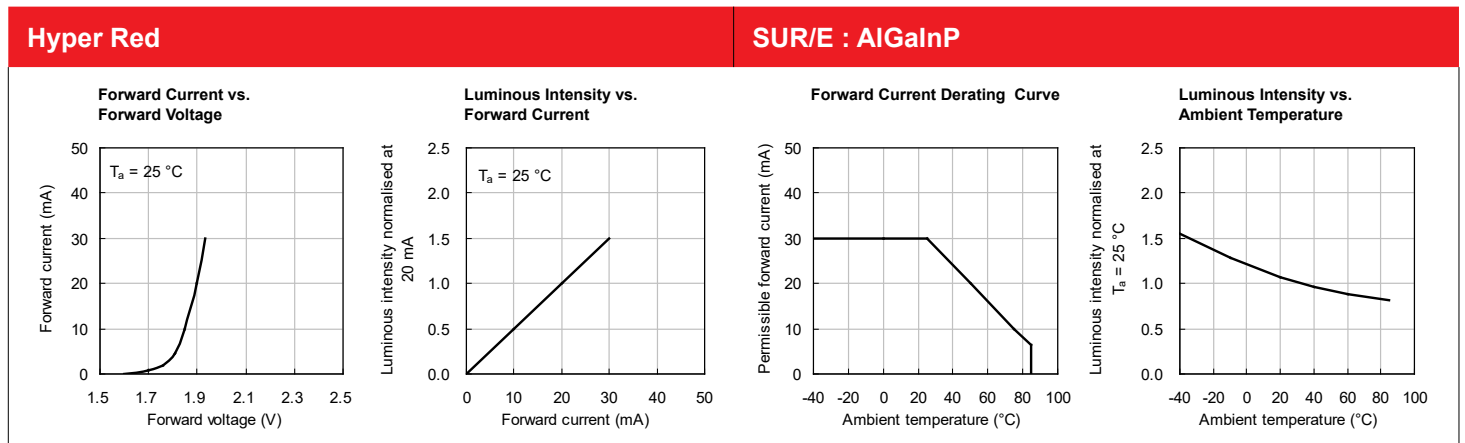
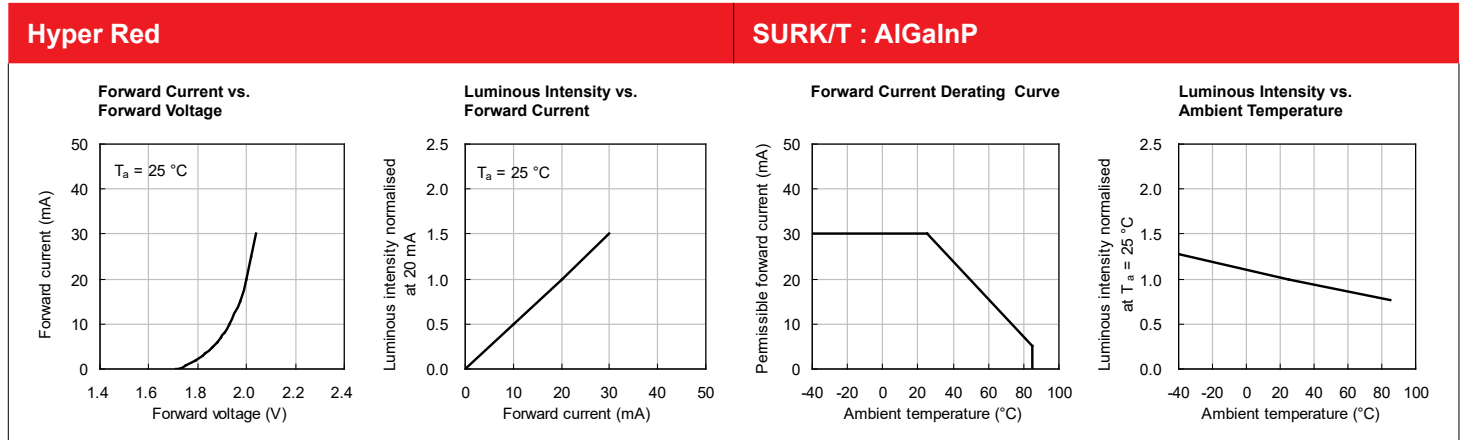

TECHNICAL DATA

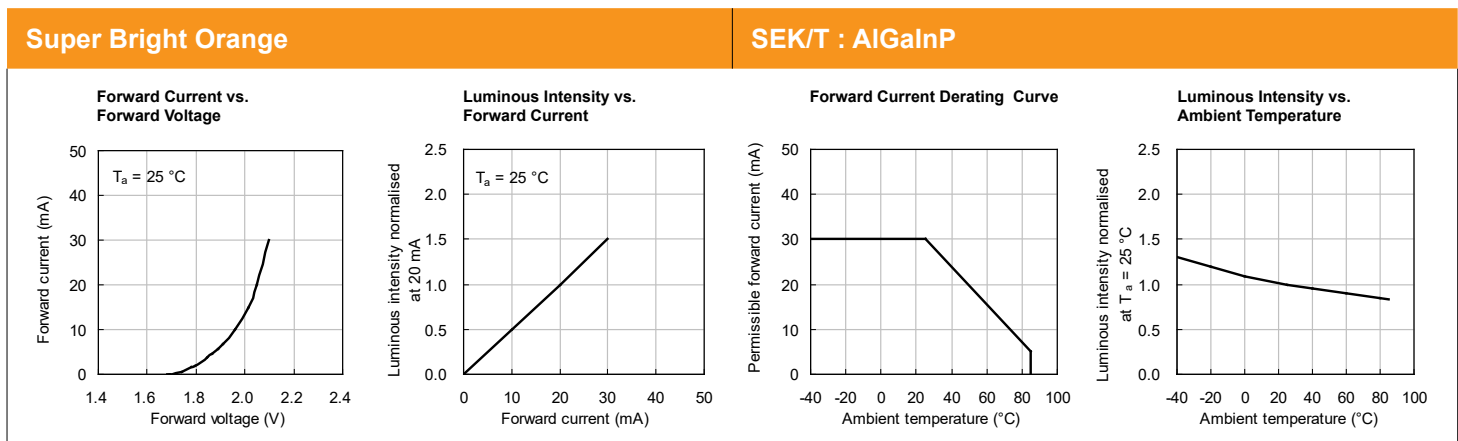
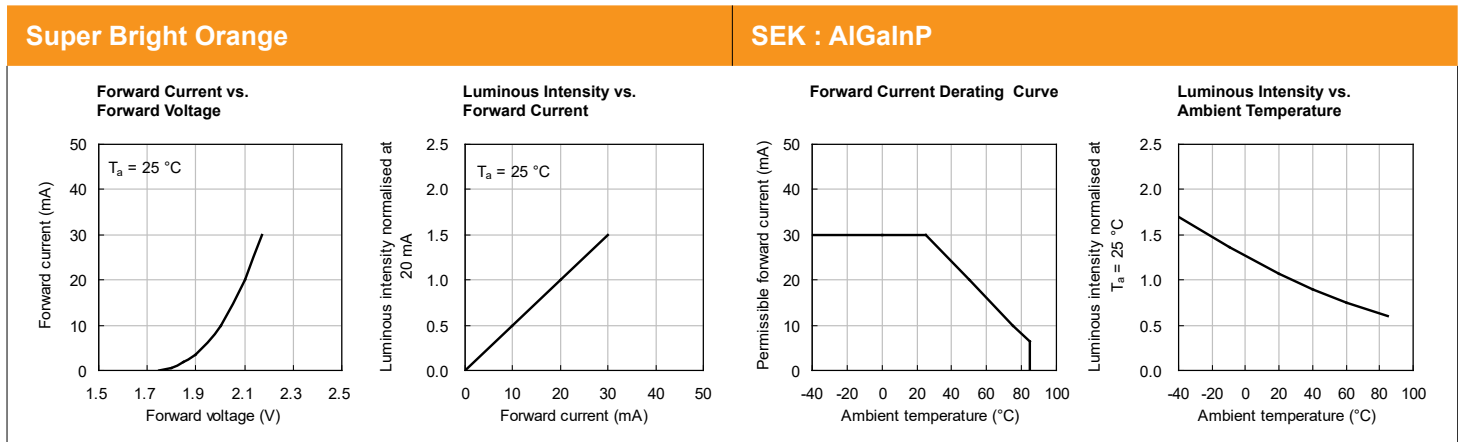
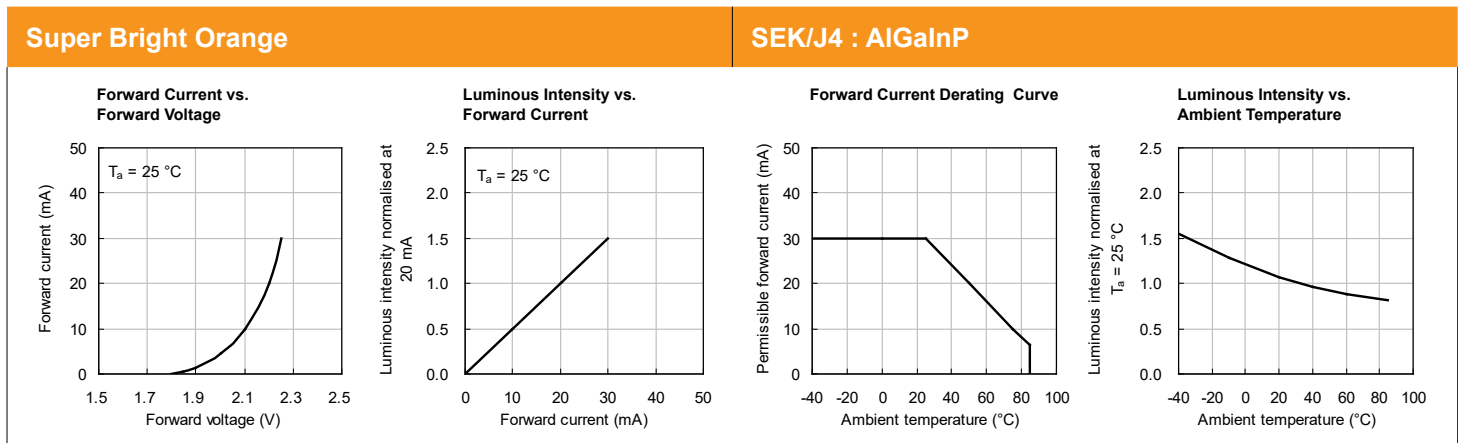
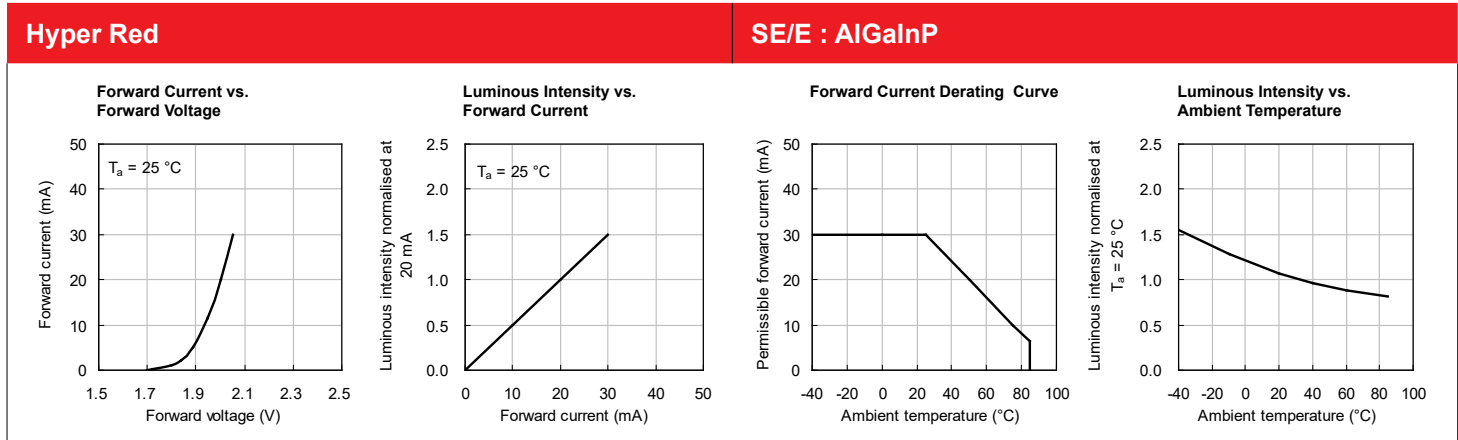

TECHNICAL DATA

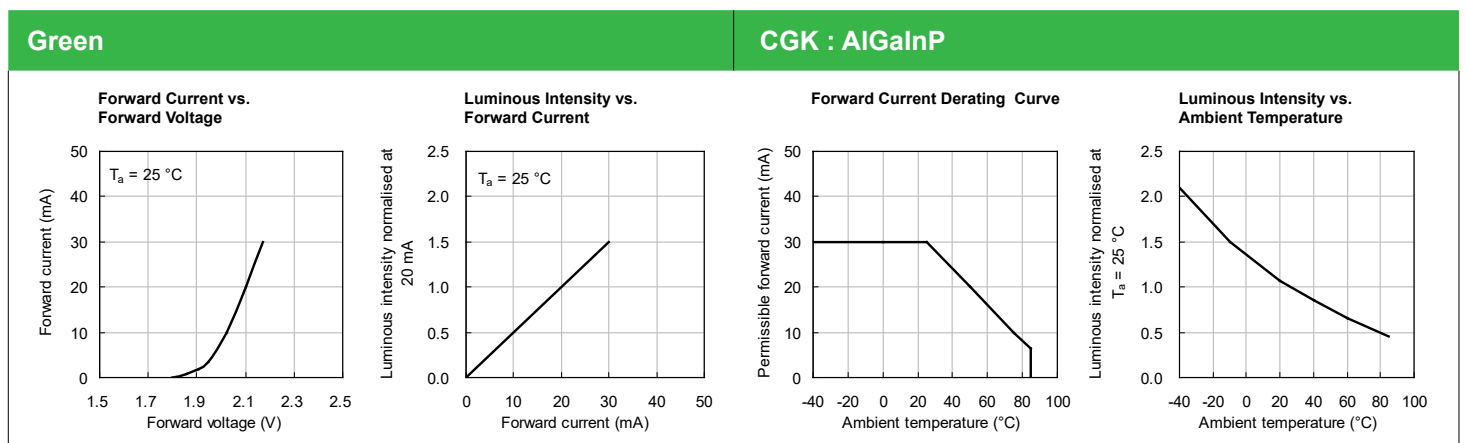
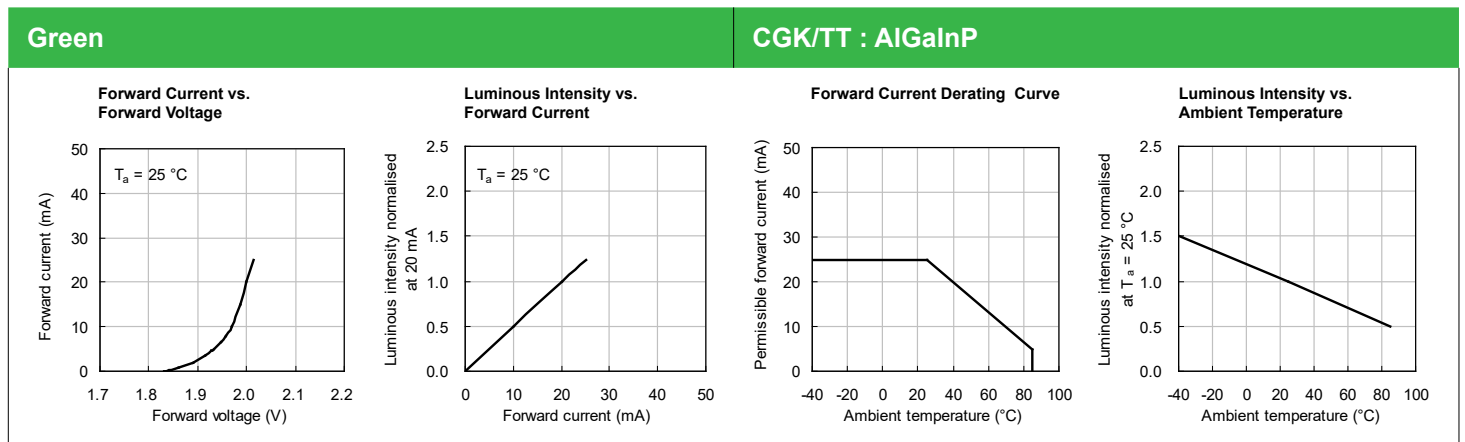
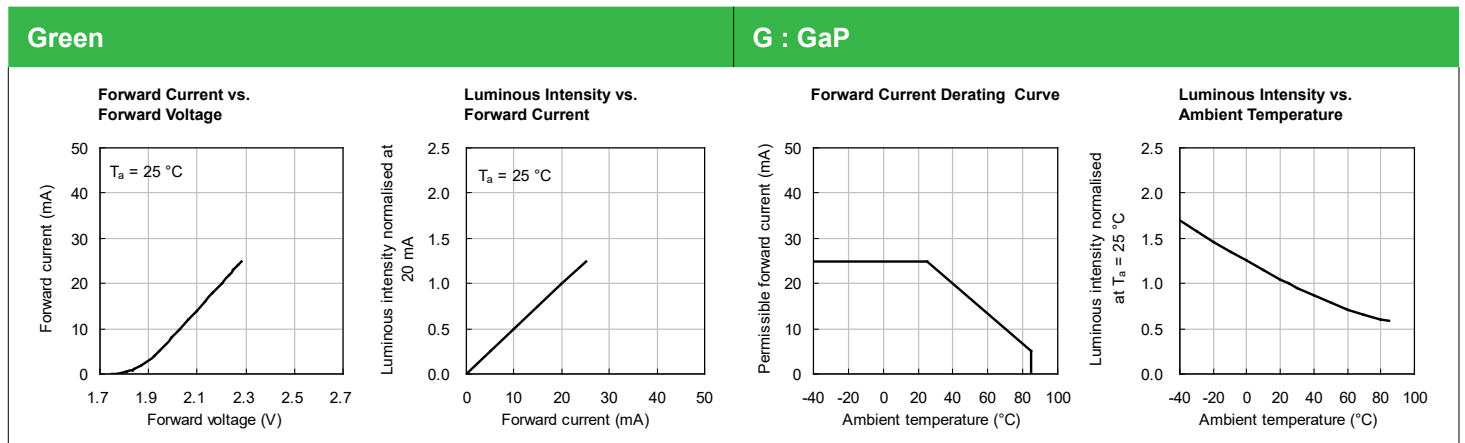
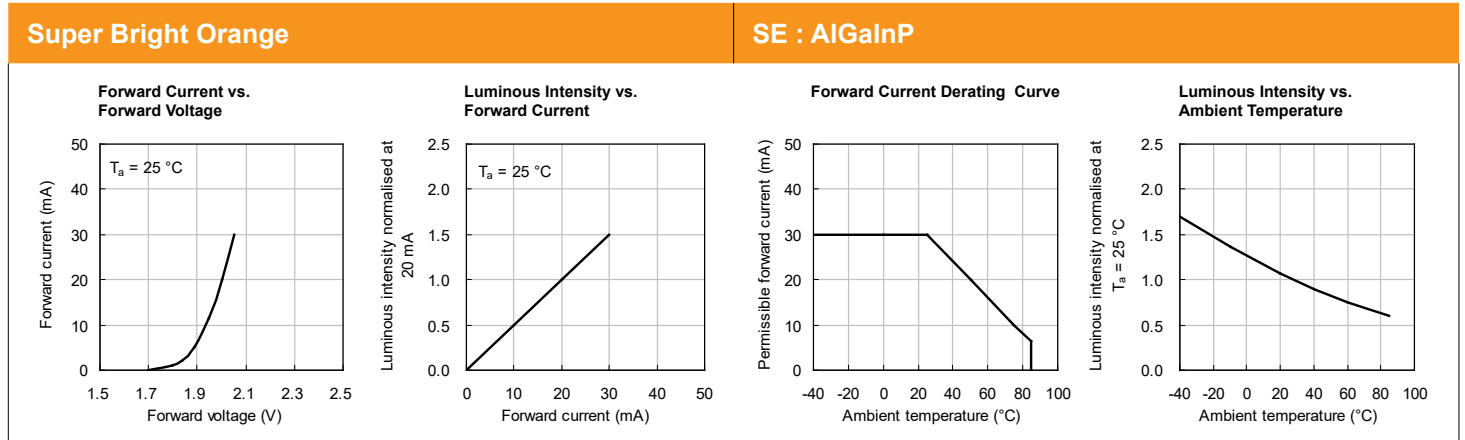

TECHNICAL DATA

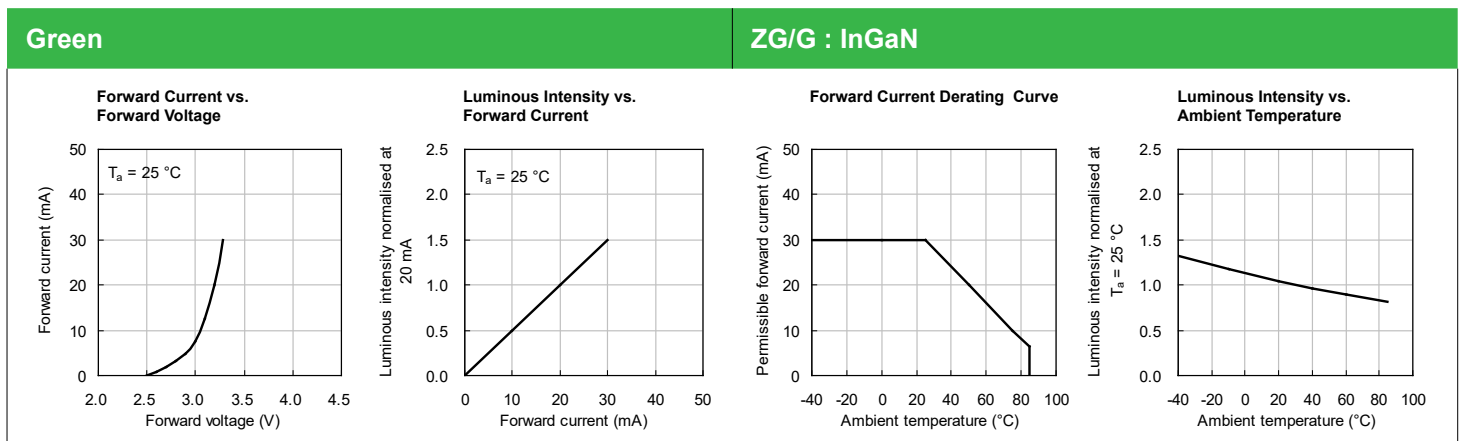
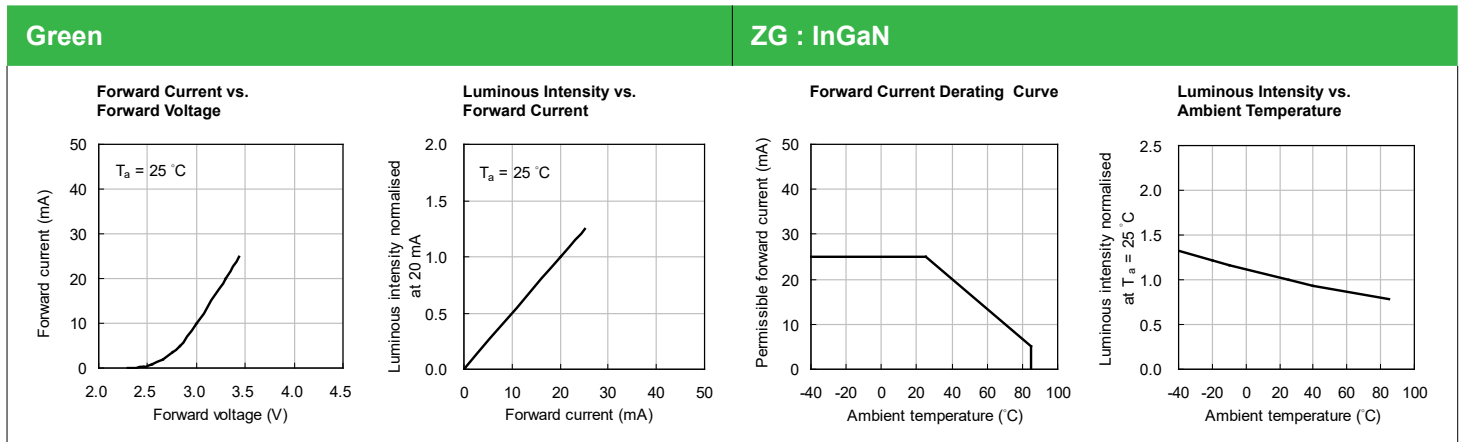
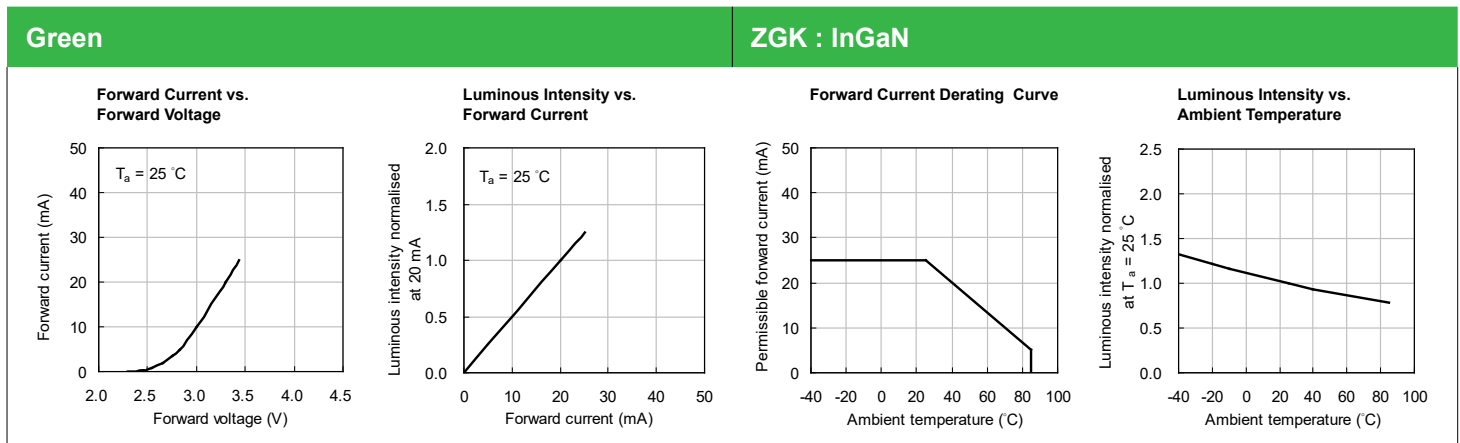
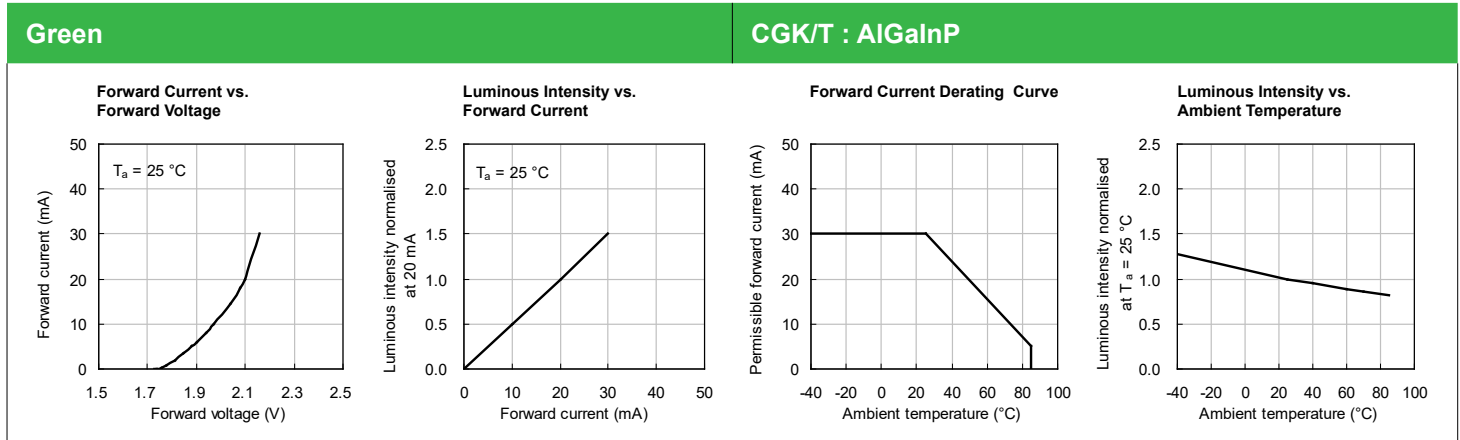

TECHNICAL DATA

Yellow

Y : GaAsP/GaP

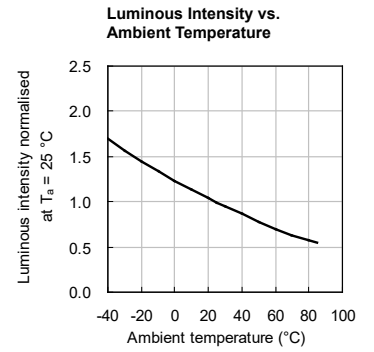
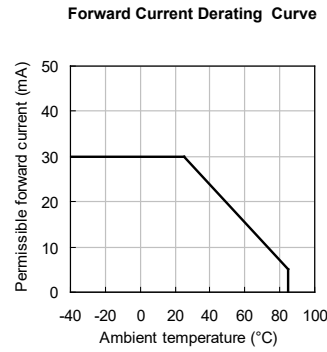
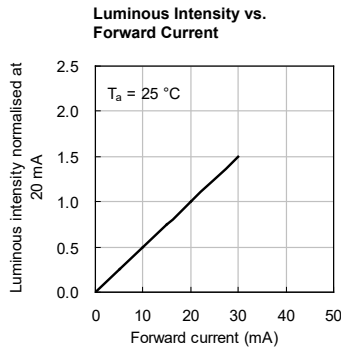
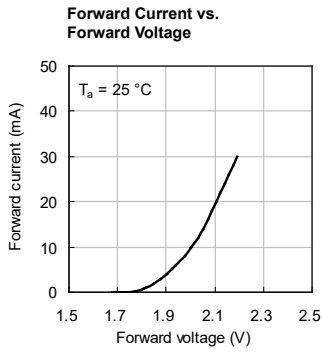

Super Bright Yellow

SYK : AlGaInP

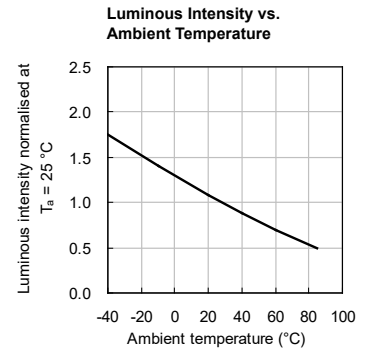
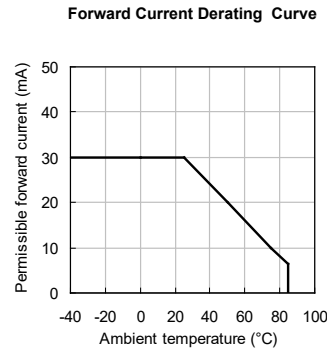
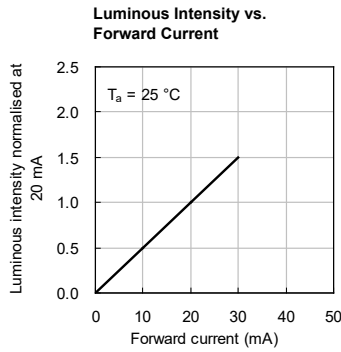
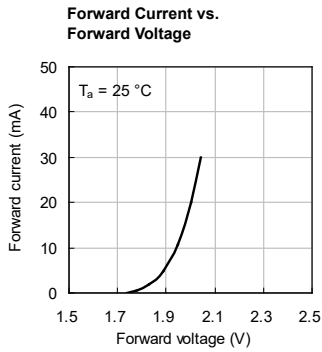

Super Bright Yellow

SYK/T : AlGaInP

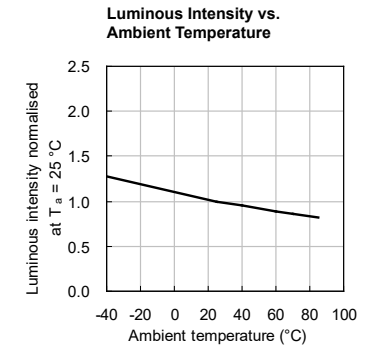
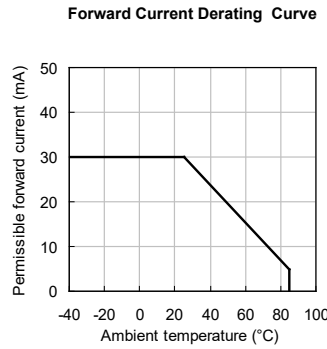
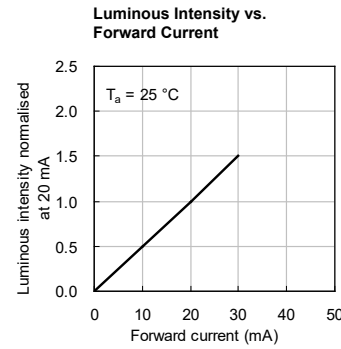
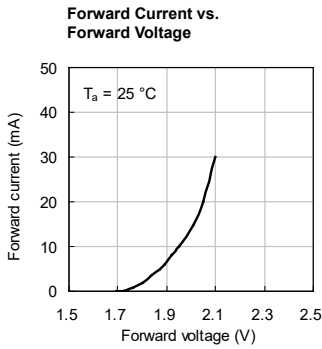

Super Bright Yellow

SY : AlGaInP

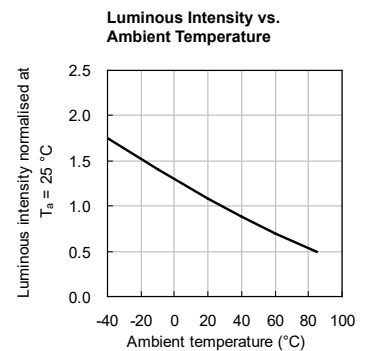
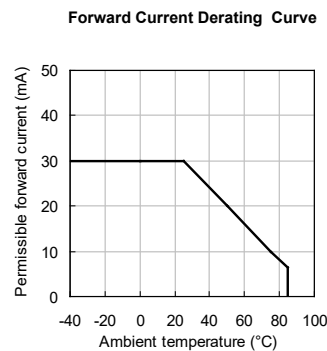
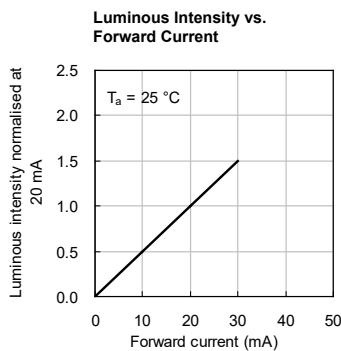
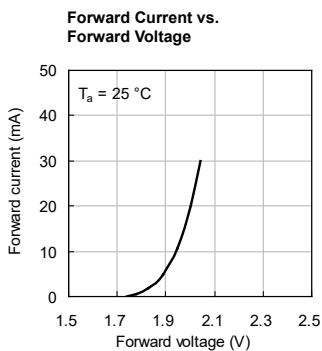



TECHNICAL DATA

Super Bright Yellow

SY/J3 : AlGaInP

Forward Current vs. Forward Voltage

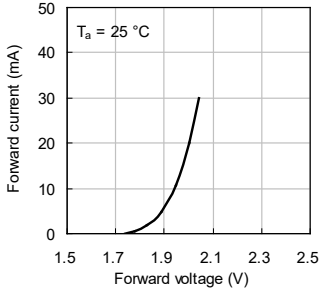

Luminous Intensity vs. Forward Current

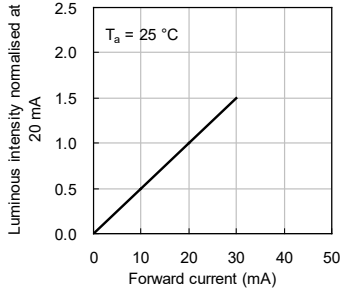

Forward Current Derating Curve

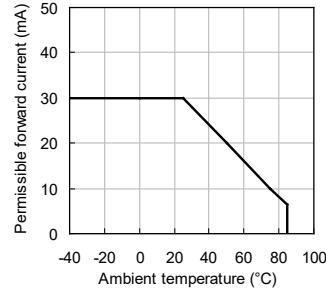

Luminous Intensity vs. Ambient Temperature

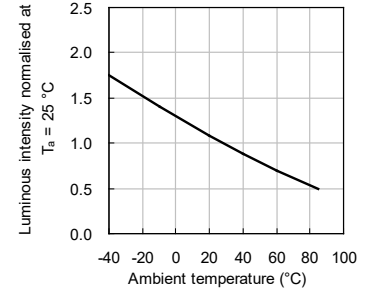

Super Bright Yellow

SYK/J3 : AlGaInP

Forward Current vs. Forward Voltage

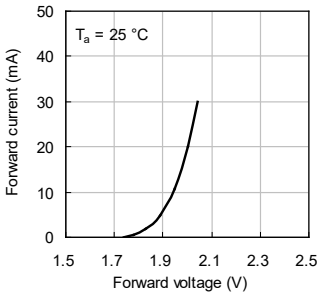

Luminous Intensity vs. Forward Current

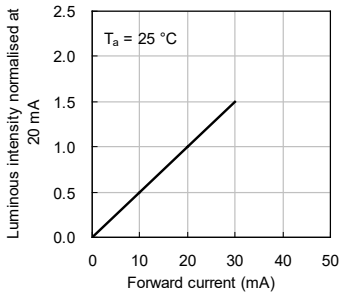

Forward Current Derating Curve

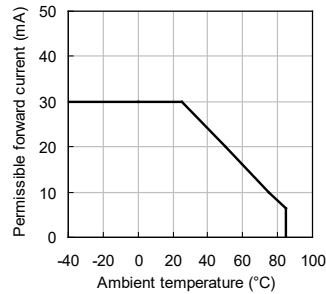

Luminous Intensity vs. Ambient Temperature

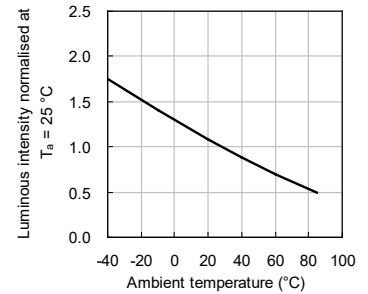

Blue

QB/D : InGaN

Forward Current vs. Forward Voltage

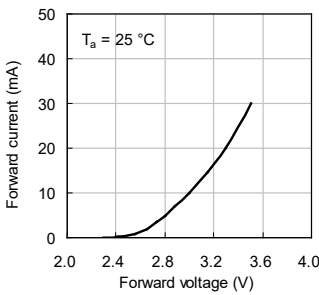

Luminous Intensity vs. Forward Current

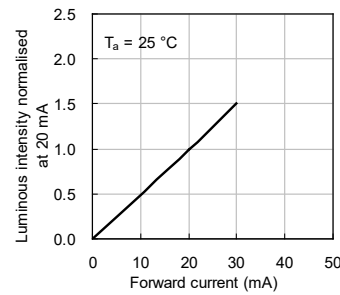

Forward Current Derating Curve

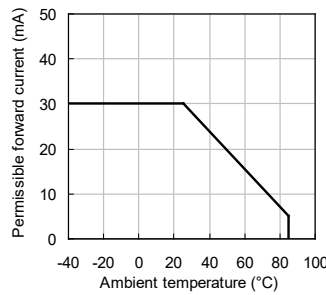

Luminous Intensity vs. Ambient Temperature

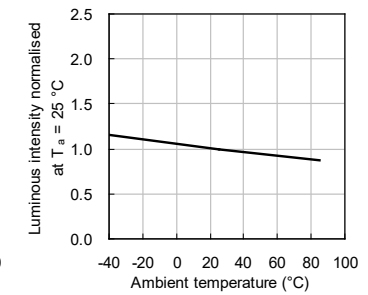

Blue

VB/D : InGaN

Forward Current vs. Forward Voltage

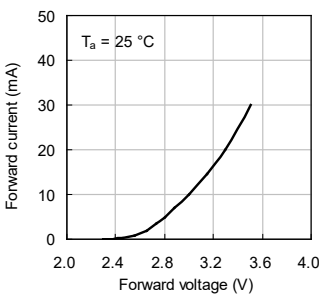

Luminous Intensity vs. Forward Current

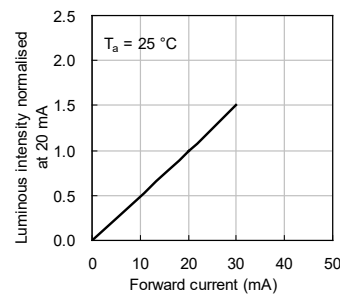

Forward Current Derating Curve

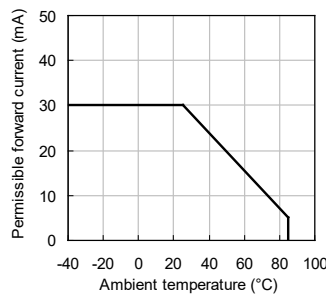

Luminous Intensity vs. Ambient Temperature

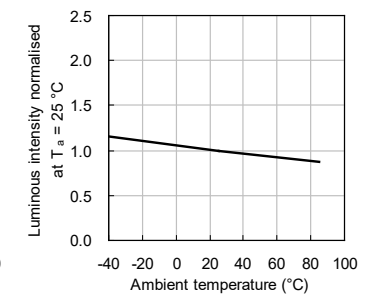

TECHNICAL DATA

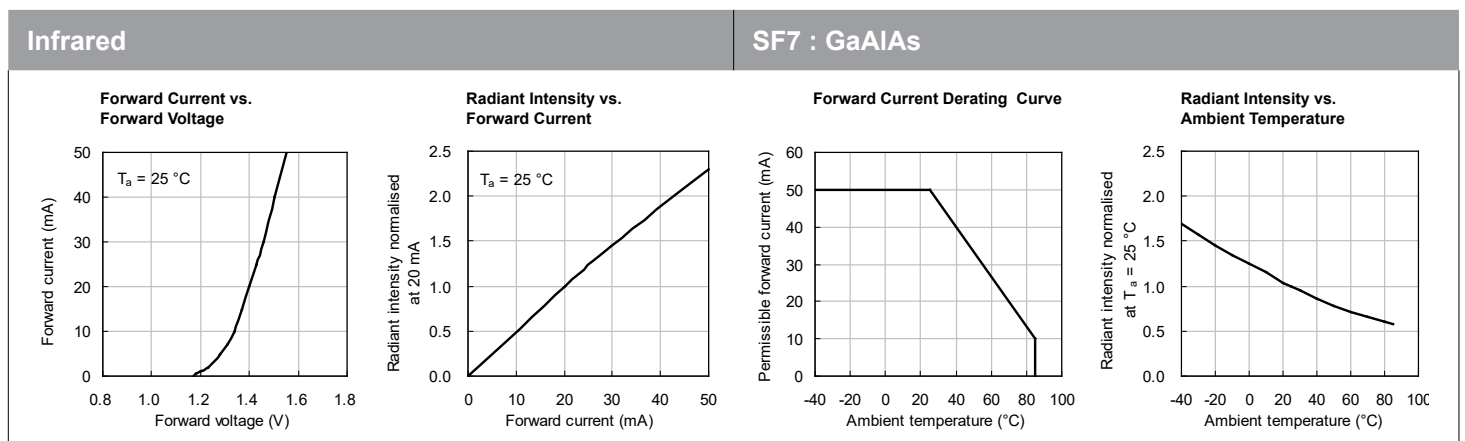
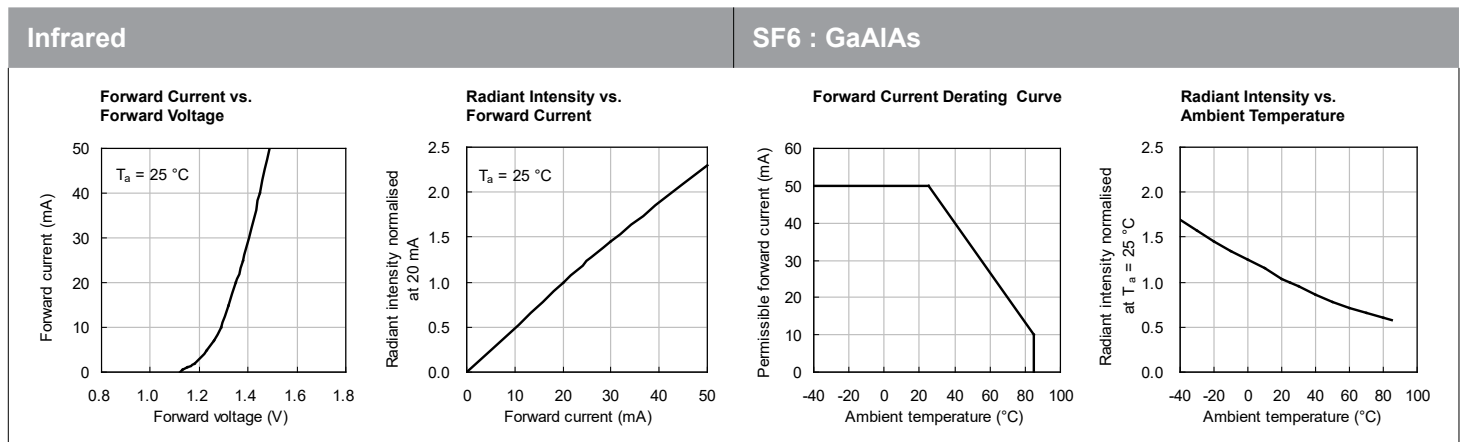
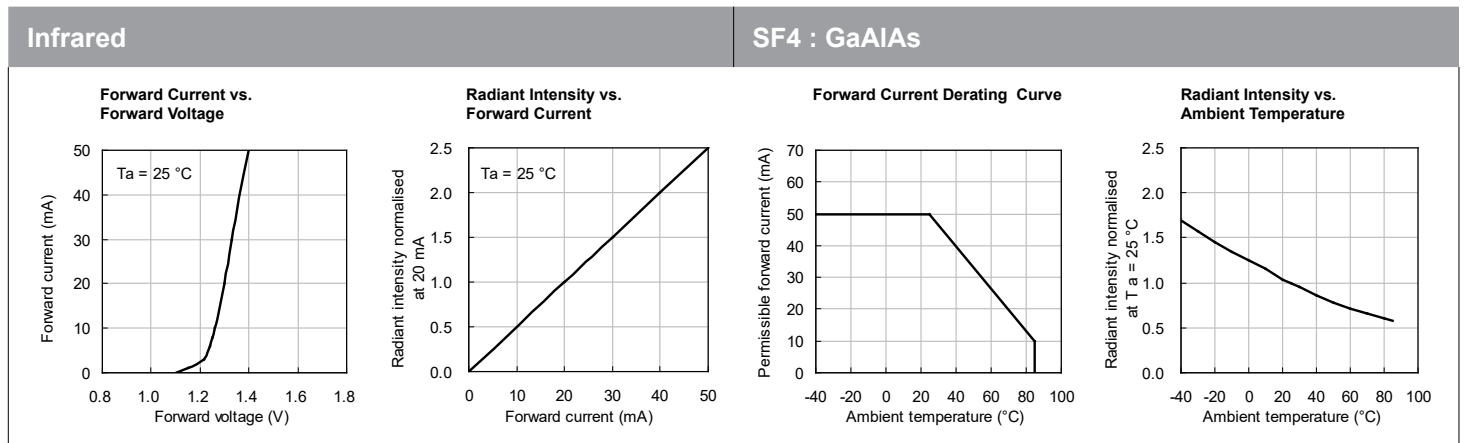
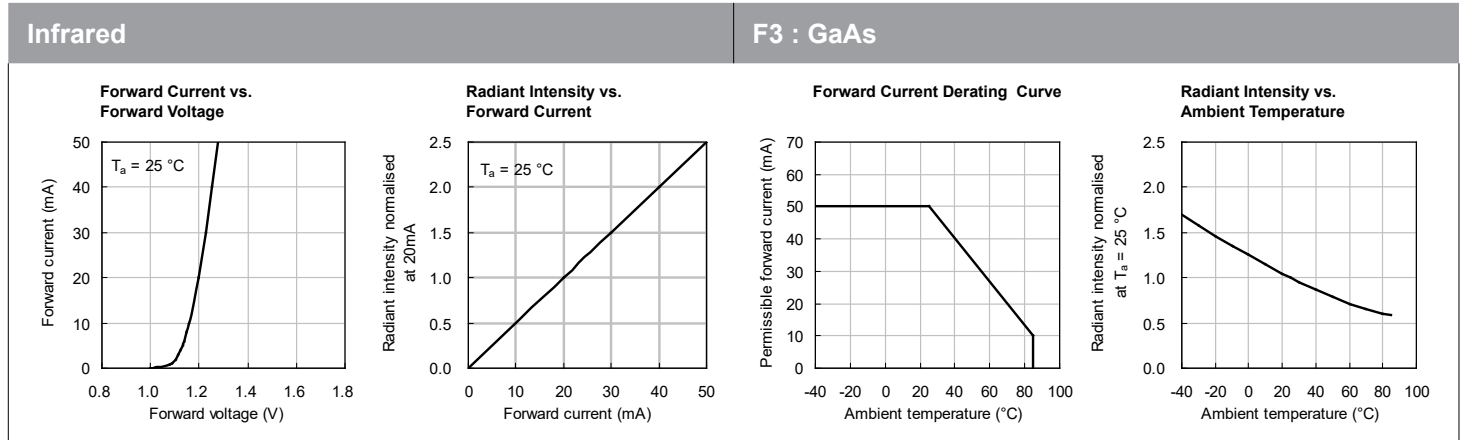

**BIN CODE SYSTEMS**

**SELECTION CODE FOR STANDARD AND LOW CURRENT LEDS**

(T<sub>A</sub>=25°C Tolerance +/-15% IF<15mA)

Group	Light intensity in mcd		Group	Light intensity in mcd	
	Min.	Max.		Min.	Max.
F	0.1	0.2	W	120	180
G	0.2	0.35	X	180	250
H	0.35	0.5	Y	250	320
I	0.5	0.8	Z	320	450
K	0.8	1.2	ZA	450	550
L	1.2	2	ZB	550	700
M	2	4	ZC	700	1000
N	4	6	ZD	1000	1600
P	6	10	ZE	1600	2200
Q	10	15	ZF	2200	2800
R	15	20	ZG	2800	3400
S	20	30	ZH	3400	4300
T	30	50	ZM	4300	5200
U	50	80	ZN	5200	6300
V	80	120	ZP	6300	7400

**SELECTION CODE FOR NPN PHOTOTRANSISTORS**

(T<sub>A</sub>=25°C Tolerance +/-15%)

Group	Photocurrent(mA)		Group	Photocurrent(mA)	
	Min.	Max.		Min.	Max.
F	0.1	0.2	L	1.2	2
G	0.2	0.35	M	2	4
H	0.35	0.5	N	4	6
I	0.5	0.8	P	6	10
K	0.8	1.2	-	-	-

**SELECTION CODE FOR INFRARED EMITTING DIODES**

(T<sub>A</sub>=25°C Tolerance +/-15%)

Group	Radiant intensity in mW/sr		Group	Radiant intensity in mW/sr	
	Min.	Max.		Min.	Max.
AK	0.8	1.2	D	8	12
AL	1.2	2	E	12	20
A	2	3	F	20	40
B	3	5	G	40	55
C	5	8	H	55	80

**SELECTION CODE FOR SUPER BRIGHT LEDS**

(T<sub>A</sub>=25°C Tolerance +/-15% IF≥15mA)

Group	Light intensity in mcd		Group	Light intensity in mcd	
	Min.	Max.		Min.	Max.
A	2	3	ZA	3100	3600
B	3	5	ZB	3600	4200
C	5	8	ZC	4200	5000
D	8	12	ZD	5000	6000
E	12	20	ZE	6000	7000
F	20	40	ZF	7000	8000
G	40	55	ZG	8000	9000
H	55	80	ZH	9000	11000
M	80	120	ZM	11000	14000
N	120	200	ZN	14000	18000
P	200	300	ZP	18000	22000
Q	300	400	ZQ	22000	27000
R	400	500	ZR	27000	35000
S	500	700	ZS	35000	43000
T	700	1000	ZT	43000	55000
U	1000	1300	ZU	55000	75000
V	1300	1600	ZV	75000	130000
W	1600	1900	ZW	130000	200000
X	1900	2300	ZX	200000	320000
Y	2300	2700	ZY	320000	490000
Z	2700	3100	ZZ	490000	800000

**SELECTION CODE FOR DISPLAYS**

(T<sub>A</sub>=25°C Tolerance +/-15% IF≤10mA)

Group	Light intensity in ucd		Group	Light intensity in ucd	
	Min.	Max.		Min.	Max.
C	70	140	P	14000	21000
D	140	240	Q	21000	31000
E	240	360	R	31000	52000
F	360	560	S	52000	88000
G	560	900	T	88000	150000
H	900	1400	U	150000	255000
I	1400	2200	V	255000	433000
K	2200	3600	W	433000	736000
L	3600	5600	X	736000	1251000
M	5600	9000	Y	1251000	2126000
N	9000	14000	Z	2126000	3614000



BIN CODE SYSTEMS

SELECTION CODE FOR LUMINOUS FLUX (T <sub>A</sub> =25°C; Tolerance: +/-15%)					
Group	Luminous Flux in lm		Group	Luminous Flux in lm	
	Min.	Max.		Min.	Max.
A1	0.5	0.6	B10	50	60
A2	0.6	0.7	B11	60	70
A3	0.7	0.8	B12	70	80
A4	0.8	1	B13	80	90
A5	1	1.2	B14	90	100
A6	1.2	1.4	C1	100	120
A7	1.4	1.7	C2	120	140
A8	1.7	2	C3	140	160
A9	2	2.4	C4	160	180
A10	2.4	2.9	C5	180	210
A11	2.9	3.5	C6	210	240
A12	3.5	4.2	C7	240	280
A13	4.2	5	C8	280	320
A14	5	6	C9	320	370
A15	6	7.2	C10	370	430
A16	7.2	8.6	C11	430	490
A17	8.6	10	C12	490	560
B1	10	12	C13	560	640
B2	12	14	C14	640	740
B3	14	17	C15	740	850
B4	17	20	C16	850	1000
B5	20	24	D1	1000	1200
B6	24	29	D2	1200	1400
B7	29	35	D3	1400	1600
B8	35	42	D4	1600	1800
B9	42	50	D5	1800	2100

COLOR CODE FOR GREEN LEDs + DISPLAYS (T <sub>A</sub> =25°C; Tolerance: +/-1nm)				
Group	Dom. Wavelength (nm)			
	Min.	Max.	Min.	Max.
0	556	559	-	-
1	559	561	515	520
2	561	563	520	525
3	563	565	525	530
4	565	567	530	535
5	567	569	535	540
6	569	571	-	-
7	571	573	-	-
8	573	575	-	-

COLOR CODE FOR BLUE LEDs + DISPLAYS (T <sub>A</sub> =25°C; Tolerance: +/-1nm)					
Group	Dom. Wavelength (nm)		Group	Dom. Wavelength (nm)	
	Min.	Max.		Min.	Max.
1	445	450	3A	471	473
2	450	455	3B	473	475
3	455	460	4A	475	477
1A	460	463	4B	477	479
1B	463	466	5A	479	481
2A	466	469	5B	481	483
2B	469	471	5C	483	486

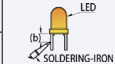
COLOR CODE FOR YELLOW LEDs + DISPLAYS (T <sub>A</sub> =25°C; Tolerance: +/-1nm)					
Group	Dom. Wavelength (nm)		Group	Dom. Wavelength (nm)	
	Min.	Max.		Min.	Max.
1	581	584	5	590	592
2	584	586	6	592	594
3	586	588	7	594	597
4	588	590	8	597	600

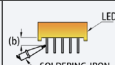
SOLDERING INSTRUCTIONS								
Types	Dip soldering / * wave soldering			Figure	Iron soldering (with 1.5mm iron tip)			Figure
	Temperature of the soldering bath	Maximum soldering time	Distance from solder joint to package (a)		Temperature of soldering iron	Maximum soldering time	Distance from solder joint to package (b)	
THROUGH-HOLE LED	<=260°C	3s	>=2mm		<=350°C	3s	>2mm	
	<=260°C	5s	>=5mm		<=350°C	5s	>5mm	
SMD	-	-	-	-	<=350°C	3s (one time only)	-	-
DISPLAY	*<=260°C	*3s	*>2mm		<=350°C	3s	>2mm	
PHOTOCOUPLER	<=260°C	3s	-	-	<=310°C	3s	-	-
	-	-	-		<=260°C	10s	-	

APPLICATION NOTES

General Notes

1. We recommend manual soldering operations only for repair and rework purposes. The soldering iron should be temperature-controlled to avoid damaging the component. The maximum soldering temperature is 300°C for Pb-Sn solder and 350°C for lead-free solder for normal lamps and displays. For blue (typ.:465nm), green (typ.:525nm), and all white LEDs, the maximum soldering iron temperature is 280°C. Do not place the soldering iron on the component for more than 3 seconds.

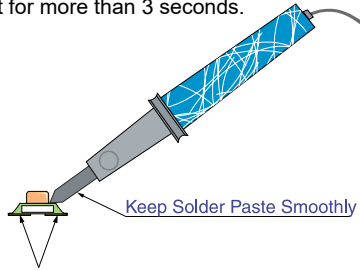

- The tip of the soldering iron should never touch the epoxy lens.
- Do not apply stress to the leads when the component is heated above 85°C, otherwise internal wire bonds may be damaged.
- Through-Hole LEDs are incompatible with reflow soldering.
- If the LED will undergo multiple soldering passes or face other processes where the part may be subjected to intense heat, please check with Kingbright for compatibility.
- SMD products must be mounted according to specified soldering pad patterns. Refer to the product datasheet for details. Solder paste must be evenly applied to each soldering pad to insure proper bonding and positioning of the component.

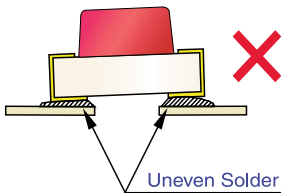

- After soldering, allow at least three minutes for the component to cool down to room temperature before further operations.
- Recommended PCB pin hole diameters for display products are listed below :

Square pin type :  $\Phi 1\text{mm}$

Round pin type : 2 x pin diameters

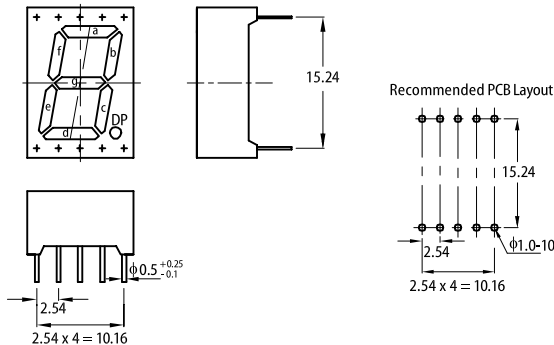

9. Data subject to change without notice. For additional detail of application notes, product information, and disclaimers, please visit our website at [www.KingbrightUSA.com/ApplicationNotes/](http://www.KingbrightUSA.com/ApplicationNotes/)

Recommended Wave Soldering Profiles For Kingbright Through-Hole Products

1. Lead-Free Wave Soldering Profile

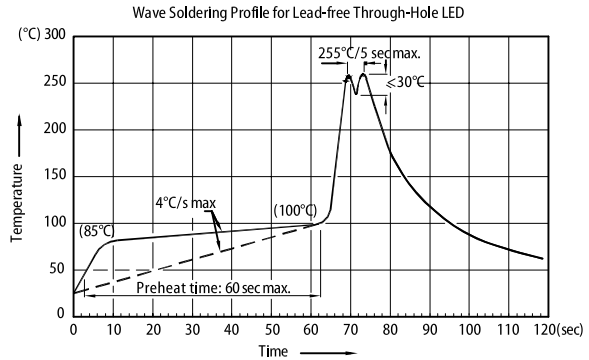

Notes:

- Recommend pre-heat temperature of 105°C or less (as measured with a thermocouple attached to the LED pins) prior to immersion in the solder wave with a maximum solder bath temperature of 260°C.
- Peak wave soldering temperature between 245°C ~ 255°C for 3 sec (5 sec max).
- Do not apply stress to the epoxy resin while the temperature is above 85°C.
- Fixtures should not incur stress on the component when mounting and during soldering process.
- SAC 305 solder alloy is recommended.
- No more than one wave soldering pass.
- During wave soldering, the PCB top-surface temperature should be kept below 105°C.

2. Wave Soldering Profile With Pb-Sn Solder

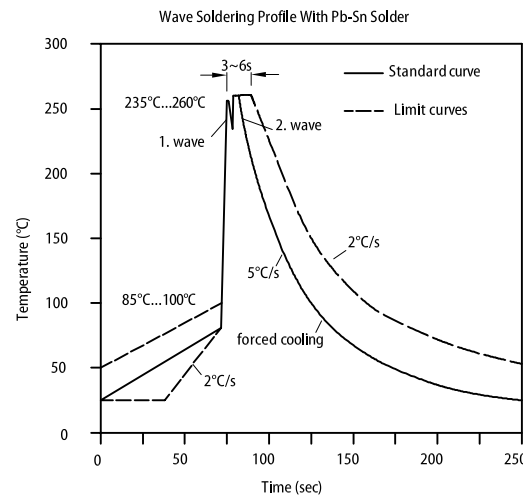

Recommended Reflow Soldering Profiles For Kingbright SMD Products

1. Lead-Free Reflow Soldering Profile

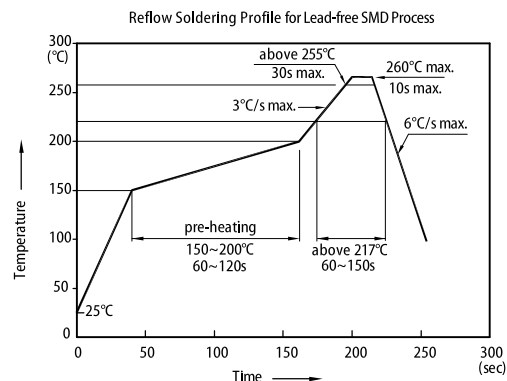

Notes:

- Don't cause stress to the LEDs while it is exposed to high temperature.
- The maximum number of reflow soldering passes is 2 times.

**2. Reflow Soldering Profiles With Pb-Sn Solder**

No more than two soldering passes with the recommended profile.

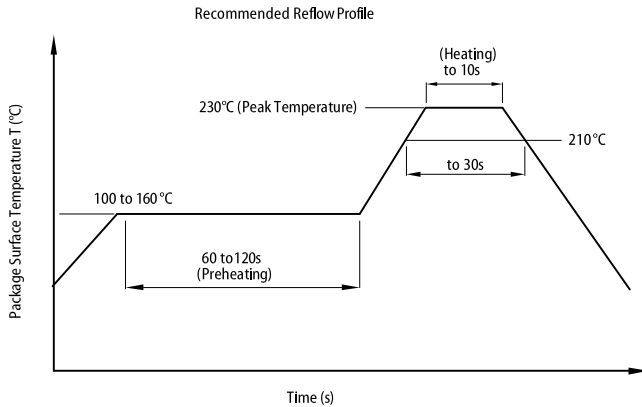

**Static Electricity and Voltage Spikes in InGaN/GaN Products**

InGaN/GaN products are sensitive to electrostatic discharge (ESD) and other transient voltage spikes. ESD and voltage spikes can affect the component's reliability, increase reverse current, and decrease forward voltage. This may result in reduced light intensity or cause component failure.

Kingbright InGaN/GaN products are stored in anti-static packaging for protection during transport and storage. Please note the anti-static measures below when handling Kingbright InGaN/GaN products.

**Design Precautions**

Products using InGaN/GaN components must incorporate protection circuitry to prevent ESD and voltage spikes from reaching the vulnerable component.

**ESD Protection During Production**

Static discharge can result when static-sensitive products come in contact with the operator or other conductors. The following procedures may decrease the possibility of ESD damage:

1. Minimize friction between the product and surroundings to avoid static buildup.
2. All manufacturing and testing equipment should be grounded.
3. All personnel in an ESD protected area should wear antistatic garments and wrist straps.
4. Set up ESD protection areas using grounded metal plating for component handling.
5. All workstations that handle IC and ESD-sensitive components must maintain an electrostatic potential of 150V or less.
6. Relative humidity levels maintained between 40% and 60% in production area are recommended to avoid the build-up of static electricity – Ref JEDEC/JESD625-A and JEDEC/J-STD-033.
7. Use anti-static packaging for transport and storage.
8. All anti-static equipment and procedures should be periodically inspected and evaluated for proper functionality.

**LED Mounting Method**

1. The lead pitch of the LED must match the pitch of the mounting holes on the PCB during component placement. Lead-forming may be required to insure the lead pitch matches the hole pitch. Refer to (Fig.1) for proper lead forming procedures.

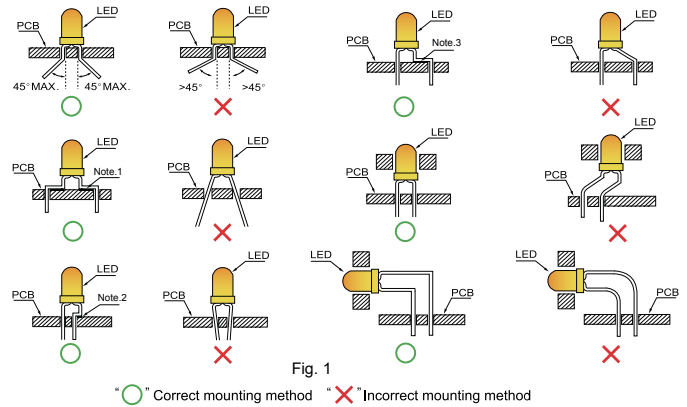

2. When soldering wires to the LED, each wire joint should be separately insulated with heat-shrink tube to prevent short-circuit contact. Do not bundle both wires in one heat shrink tube to avoid pinching the LED leads. Pinching stress on the LED leads may damage the internal structures and cause failure. (Fig.2)

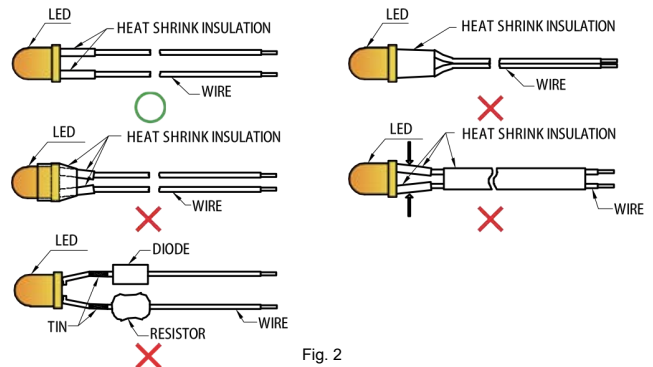

3. Use stand-offs (Fig.3) or spacers (Fig.4) to securely position the LED above the PCB.

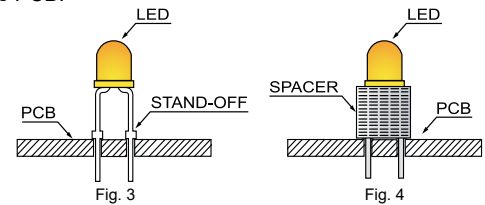

4. Do not route PCB trace in the contact area between the leadframe and the PCB to prevent short-circuits.

**Lead Forming Procedures**

1. Maintain a minimum of 3mm clearance between the base of the LED lens and the first lead bend. (Fig. 5 and 6)

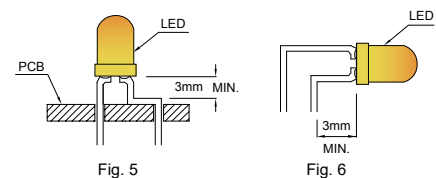

- Lead forming or bending must be performed before soldering, never during or after soldering.
- Do not stress the LED lens during lead-forming in order to prevent fractures in the epoxy lens and damage the internal structures.
- During soldering, component covers and holders should leave clearance to avoid placing damaging stress on the LED during soldering. (Fig. 7)

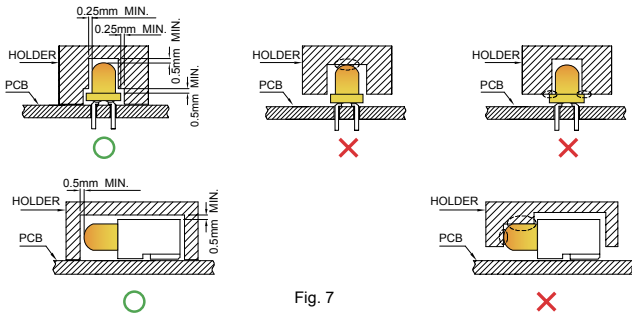

Fig. 7

- During lead forming, use tools or jigs to hold the leads securely so that the bending force will not be transmitted to the LED lens and its internal structures. Do not perform lead forming once the component has been mounted onto the PCB. (Fig. 8)

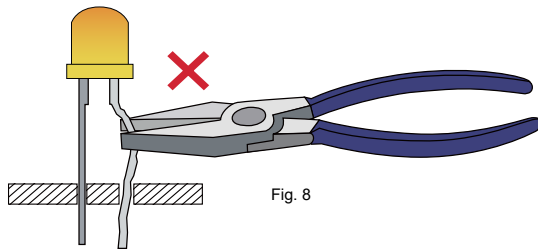

Fig. 8

- Do not bend the leads more than twice. (Fig. 9)

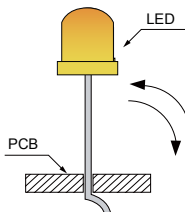

Fig. 9

- After soldering or other high-temperature assembly, allow the LED to cool down to 50°C before applying outside force. (Fig. 10)  
In general, avoid placing excess force on the LED to avoid damage. For any questions, please consult with Kingbright representative for proper handling procedures.

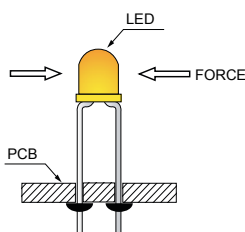

Fig. 10

Cleaning

For SMD and through-hole LEDs

- Isopropyl alcohol or deionized water are recommended for cleaning. Do not use acidic solvents or unknown chemicals, as they might cause corrosion or damage to the component.
- Lightly wipe away any surface contaminants, and allow the component to dry under room temperature before further usage. Do not soak the component in solution.

For LED Displays

- The component should be washed with only water, and immediately dried by forced-air to remove excess moisture. Do not use harsh organic solvents because they might damage the plastic parts.
- The cleaning process should take place at room temperature and the component should not be washed for more than one minute.

Miscellaneous Design Notes

- Protective current-limiting resistors may be necessary to operate the LEDs within the specified range.
- LEDs mounted in parallel should each be placed in series with its own current-limiting resistor.

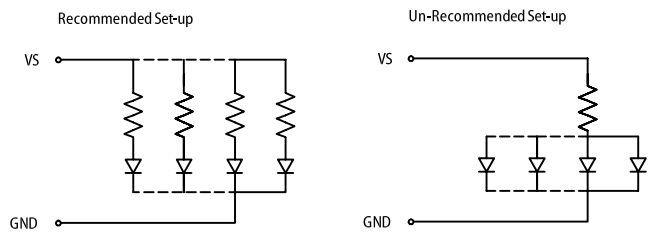

- The driving circuit should be designed to avoid reverse voltages and transient voltage spikes when the circuit is powered up or shut down.
- High temperatures can reduce device performance and reliability. Keep LED devices away from heat source for best performance.
- The safe operation current should be chosen after considering the maximum ambient temperature of the operating environment.
- During soldering, SMD components should be mounted such that the leads are placed perpendicular to the direction of PCB travel to ensure the solder on each lead melts simultaneously during reflow.

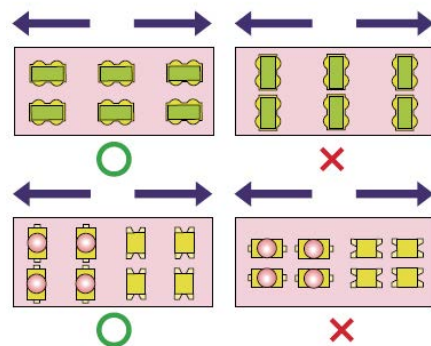

- Optimal usage of high-power LED devices requires careful design by the end-user to optimize heat dissipation, such as increasing the size of the metal backing around the soldering pad. Refer to the product datasheet for specific design recommendations regarding heat dissipation.

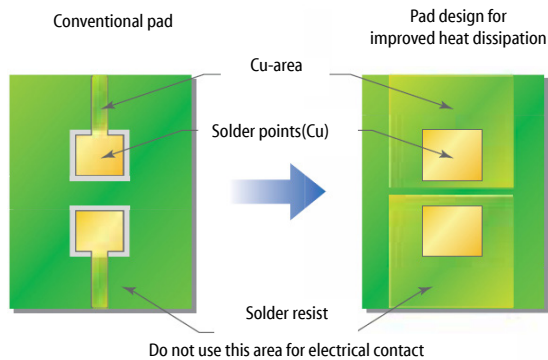

**Restrictions on Product Use**

1. Not all devices and product families are available in every country.
2. The light output from UV, blue, white, and other high-power LEDs may cause injury to the human eye when viewed directly.
3. LED devices may contain gallium arsenide (GaAs) material. GaAs is harmful if ingested. GaAs dust and fumes are toxic. Do not break, cut, or pulverize LED devices. Do not dissolve LEDs in chemical solvents.
4. Semiconductor devices can fail or malfunction due to their sensitivity to electrical fluctuation and physical stress. It is the responsibility of the user to observe all safety standards when using Kingbright products, in order to avoid situations in which the malfunction or failure of a Kingbright product could cause injury, property damage, or the loss of human life. In developing designs, please insure that Kingbright products are used within specified operating conditions as set forth in the most recent product specification datasheet.
5. For LEDs with silicone encapsulation such as the AA series, the outer diameter of the pick-up nozzle must be longer than that of the LED's light emitting area. i. e.  $A > C$ , and B shall be shorter than the width of the LED.

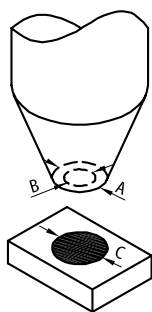

A is the outer diameter of the pick-up nozzle  
 B is the inner diameter of the pick-up nozzle  
 C is the diameter of lens

6. The size of the nozzle should be as large as possible if the tape is not involved.
7. The LEDs should not be exposed to an environment where high level of moisture or corrosive gases are present.
8. Prolonged reverse bias should be avoided, as it could cause metal migration, leading to an increase in leakage current or causing a short circuit.
9. Excess driving current and/or operating temperature higher than recommended conditions may result in severe light degradation or premature failure.

10. It is not recommended to assemble LEDs of different color or intensity bins together, as there may be perceivable color or intensity variation. Each bag contains parts from the same bin code. The bin code is printed on the bag's label as below.

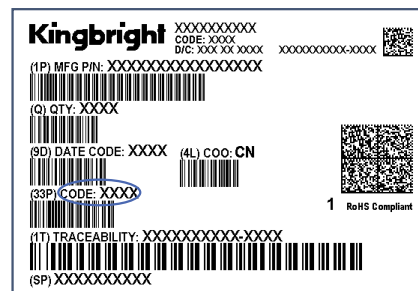

11. For the 0603, 1005 and 1608 series, an ESD ionizer should be used during SMT pick-and-place process to neutralize the charge and hence reduce electrostatic attraction.
12. Please do not apply stress directly to the LED during handling.
13. As silicone encapsulation is permeable to gases, some corrosive substances such as  $H_2S$  might corrode silver plating of leadframe. Special care should be taken if an LED with silicone encapsulation is to be used near such substances.
14. The LEDs should not be exposed to an environment where high level of moisture or corrosive gases are present.
15. For right angle SMD LEDs, the solder stencil should be at least 5mil in thickness, to prevent poor solder wetting due to insufficient solder paste.
16. Choosing the right feeder for small SMD components:
  - 16.1 When processing smaller SMD components (such as 0603, 1005, 1608, 1612, 1615, 2012), please use feeder with block to hold the part in place during cover tape removal, in order to prevent the component jumping or turning within the tape due to vibration or static cling.
  - 16.2 Feeder without block is more suitable for larger size components (such as 3216, 3528).
  - 16.3 Please insure the removed cover tape is properly threaded through the feeder as it is removed from the tape.

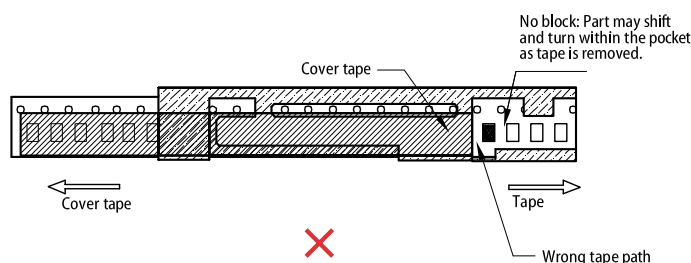
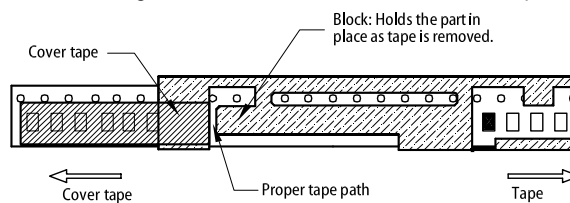



17. When placing reverse-mount LEDs, the nozzle must not place pressure on the part. Refer to the figures below, pressure on the LED will cause the LED to bend and potentially cause delamination or cracking between the component PCB and the epoxy lens. The damaged LED will be more prone to failure after undergoing high-temperature reflow soldering process.

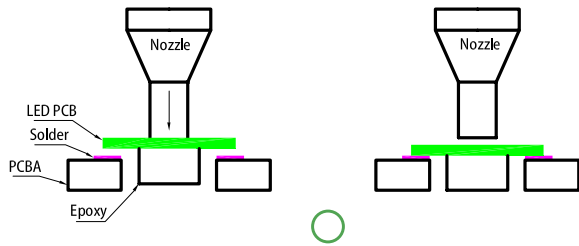

Proper SMD placement. Nozzle does not press down on the LED.

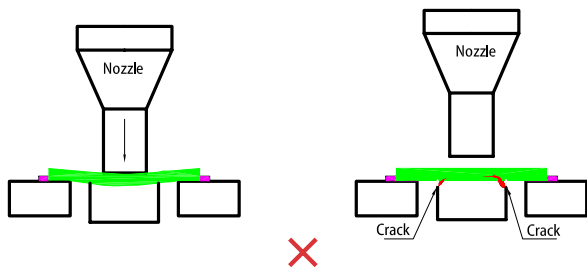

Pressure from the nozzle can cause structural damage to the LED.

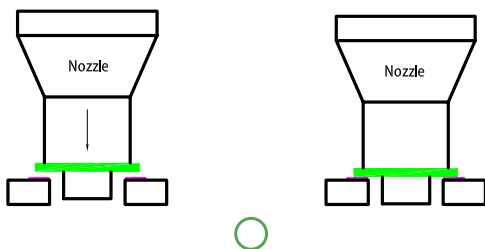

Consider using wider nozzles with diameter greater than the PCB hole opening. This will prevent pressure damage during placement.

**Storage Control For SMD Products**

1. Before a sealed moisture barrier bag (MBB) is opened, contained LEDs shall be kept in an environment with temperature below 40°C and humidity below 90% RH. MBB shall be kept sealed until LEDs contained in the bag are ready to be used. Once MBB is opened, it shall be stored in an environment with temperature range of 5°C~30°C and humidity below 60% RH.
2. After the MBB has been opened, the LEDs should be used according to the floor life specified in the table below.

**IPC/JEDEC J-STD-020 Moisture Sensitivity Levels**

Level	Floor Life	
	Time	Conditions
1	Unlimited	≤30°C / 85% RH
2	1 year	≤30°C / 60% RH
2a	4 weeks	≤30°C / 60% RH
3	168 hours	≤30°C / 60% RH
4	72 hours	≤30°C / 60% RH
5	48 hours	≤30°C / 60% RH
5a	24 hours	≤30°C / 60% RH
6	Time on Label (TOL)	≤30°C / 60% RH

3. If the Humidity Indicator Card (HIC)'s 10% mark has changed, or the LEDs have not been used within the floor life specified, they should be baked with the following conditions to reset the floor life:

Type	Temperature	Humidity	Bake Time
When still in carrier tape	60±3°C	<5%RH	100H
When out of carrier tape	110°C	/	10H

\* Not more than once

4. Do not store LEDs in an environment where high humidity or acidic/basic chemicals are present, as they will degrade the LED's metallic surfaces.
5. LED leadframe and soldering pads (cathode and anode) are plated with gold, tin, or other metals. Under long-term exposure to open air, the exposed pins and pads may become oxidized causing poor solderability. Therefore opened but unused parts must be stored in sealed containers. Suggest to store unused parts in the original moisture barrier bag.
6. Moisture control for components already mounted on PCB: If the PCB will not undergo additional reflow soldering or high-temperature processes, then no special treatment is required for the mounted moisture-sensitive SMD components. If the PCB will undergo multiple reflow soldering or other high-temperature processes, including rework, then the SMD component's cumulative exposure time until the final high-temperature process must be controlled to within the specified time limit.

**For Through-Hole Products**

1. Avoid continued exposure to the condensing moisture environment and keep the product away from rapid transitions in ambient temperature.
2. LEDs should be stored with temperature ≤30°C and relative humidity < 60%.
3. Product in the original sealed package is recommended to be assembled within 72 hours of opening. Product in opened package for more than a week should be baked for 30 (+10/-0) hours at 85 ~ 100°C.
4. The LED leadframe surface is plated with tin. When the leadframe is stored under high-humidity environments, or exposed to certain chemical elements or gases, the surface may become discolored. Please maintain the cleanliness of the storage environment.
5. If the storage conditions do not meet specification standards, the component pins may become oxidized requiring re-plating and re-sorting before use. Suggest customers consume LEDs as soon as possible, and avoid long-term storage of large inventories.

CIE CHROMATICITY DIAGRAM

White Bin Code

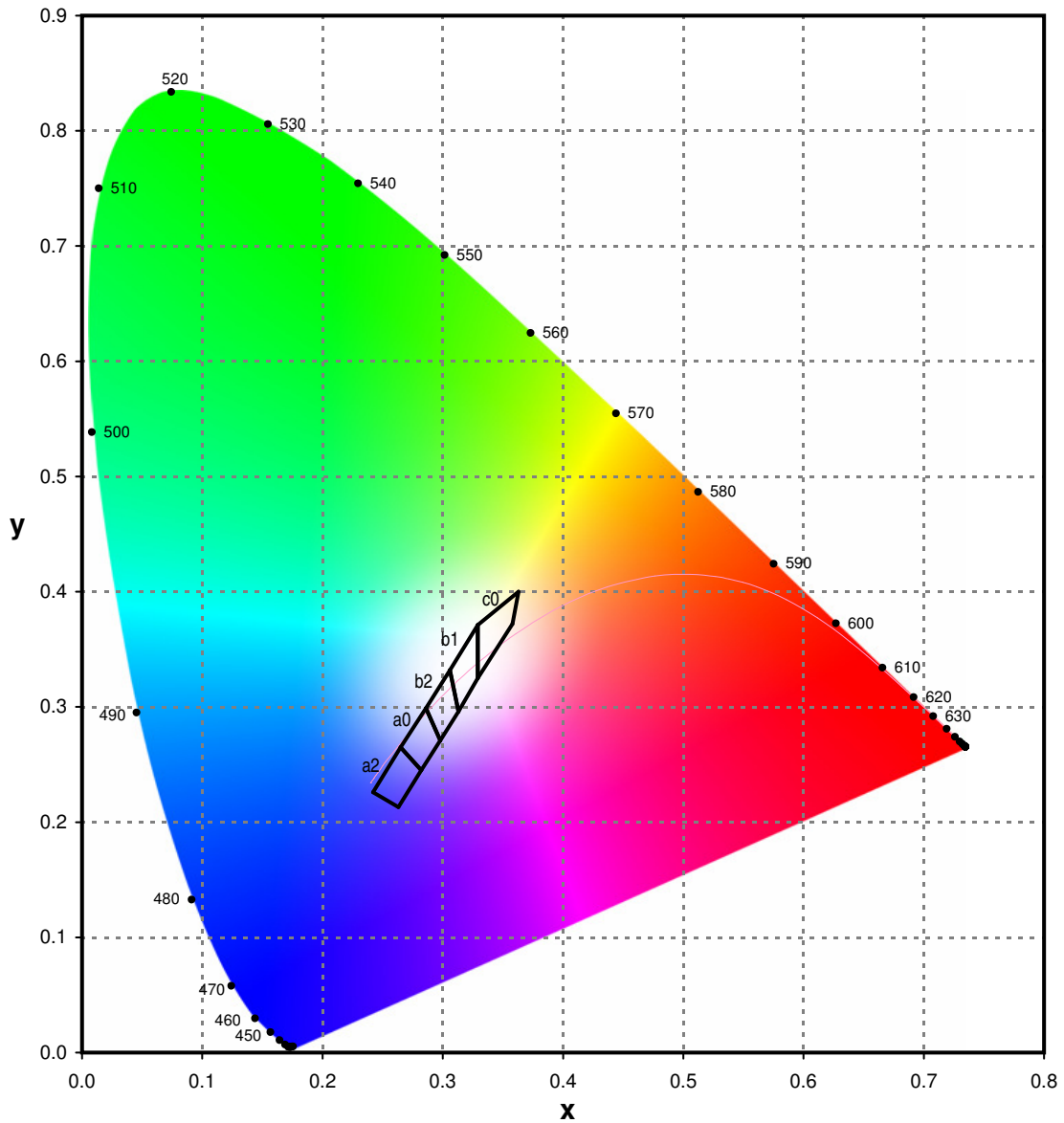

Bin	x	y
a2	0.263	0.213
	0.282	0.245
	0.265	0.265
	0.242	0.226
CCT: 15000K~		

Bin	x	y
b2	0.298	0.271
	0.313	0.296
	0.306	0.332
	0.286	0.299
CCT: 6800~9000K		

Bin	x	y
c0	0.329	0.325
	0.358	0.372
	0.363	0.400
	0.329	0.371
CCT: 4600~5600K		

Bin	x	y
a0	0.282	0.245
	0.298	0.271
	0.286	0.299
	0.265	0.265
CCT: 9000~15000K		

Bin	x	y
b1	0.313	0.296
	0.329	0.325
	0.329	0.371
	0.306	0.332
CCT: 5600~6800K		

CIE CHROMATICITY DIAGRAM

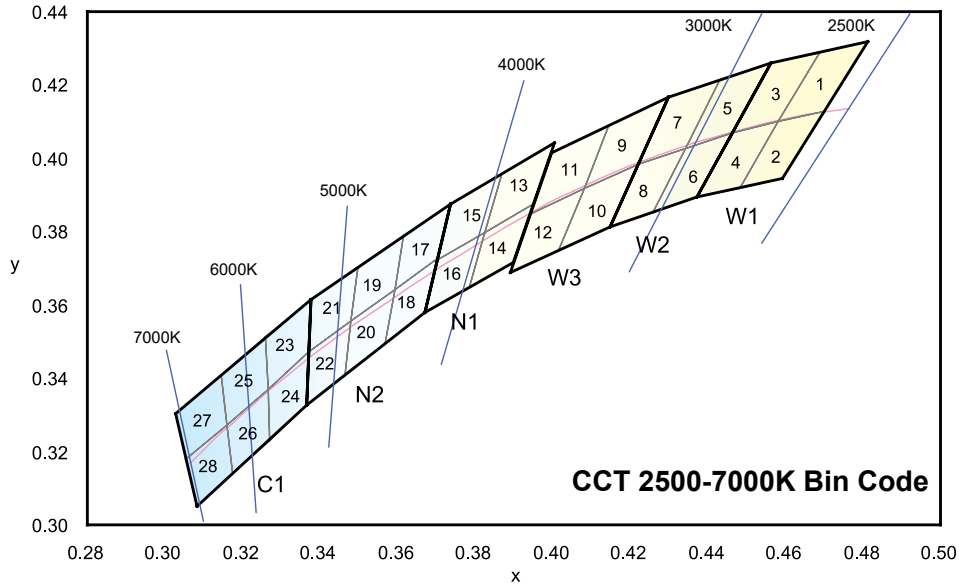

Group	Chromaticity Regions	CCT (K)			Group	Chromaticity Regions	CCT (K)		
		Min.	Typ.	Max.			Min.	Typ.	Max.
W1	1, 2, 3, 4	2580	2700	2870	N1	13, 14, 15, 16	3710	4000	4260
W2	5, 6, 7, 8	2870	3000	3220	N2	17, 18, 19, 20, 21, 22	4260	4700	5310
W3	9, 10, 11, 12	3220	3500	3710	C1	23, 24, 25, 26, 27, 28	5310	6000	7040

	x	y		x	y		x	y		x	y
1	0.4582	0.4099	8	0.4147	0.3814	15	0.3702	0.3722	22	0.3481	0.3557
	0.4687	0.4289		0.4221	0.3984		0.3736	0.3874		0.3370	0.3472
	0.4813	0.4319		0.4342	0.4028		0.3869	0.3958		0.3364	0.3328
	0.4700	0.4126		0.4259	0.3853		0.3825	0.3798		0.3466	0.3411
2	0.4483	0.3919	9	0.4080	0.3916	16	0.3670	0.3578	23	0.3376	0.3616
	0.4582	0.4099		0.4146	0.4089		0.3702	0.3722		0.3260	0.3512
	0.4700	0.4126		0.4299	0.4165		0.3825	0.3798		0.3265	0.3371
	0.4593	0.3944		0.4221	0.3984		0.3783	0.3646		0.3370	0.3472
3	0.4465	0.4071	10	0.4017	0.3751	17	0.3736	0.3874	24	0.3370	0.3472
	0.4562	0.4260		0.4080	0.3916		0.3616	0.3788		0.3265	0.3371
	0.4687	0.4289		0.4221	0.3984		0.3592	0.3641		0.3270	0.3230
	0.4582	0.4099		0.4147	0.3814		0.3703	0.3726		0.3364	0.3328
4	0.4373	0.3893	11	0.3941	0.3848	18	0.3703	0.3726	25	0.3260	0.3512
	0.4465	0.4071		0.3996	0.4015		0.3592	0.3641		0.3144	0.3408
	0.4582	0.4099		0.4146	0.4089		0.3568	0.3495		0.3160	0.3274
	0.4483	0.3919		0.4080	0.3916		0.3670	0.3578		0.3265	0.3371
5	0.4342	0.4028	12	0.3889	0.3690	19	0.3616	0.3788	26	0.3265	0.3371
	0.4430	0.4212		0.3941	0.3848		0.3496	0.3702		0.3160	0.3274
	0.4562	0.4260		0.4080	0.3916		0.3481	0.3557		0.3175	0.3139
	0.4465	0.4071		0.4017	0.3751		0.3592	0.3641		0.3270	0.3230
6	0.4259	0.3853	13	0.3825	0.3798	20	0.3592	0.3641	27	0.3144	0.3408
	0.4342	0.4028		0.3869	0.3958		0.3481	0.3557		0.3028	0.3304
	0.4465	0.4071		0.4006	0.4044		0.3466	0.3411		0.3055	0.3177
	0.4373	0.3893		0.3950	0.3875		0.3568	0.3495		0.3160	0.3274
7	0.4221	0.3984	14	0.3783	0.3646	21	0.3496	0.3702	28	0.3160	0.3274
	0.4299	0.4165		0.3825	0.3798		0.3376	0.3616		0.3055	0.3177
	0.4430	0.4212		0.3950	0.3875		0.3370	0.3472		0.3081	0.3049
	0.4342	0.4028		0.3898	0.3716		0.3481	0.3557		0.3175	0.3139

INDEX

AA1608 SERIES.....	P-14	APDA3020F3C-P22 .....	P-40	APTR3216 SERIES.....	P-23
AA2810A SERIES .....	P-16	APDA3020L SERIES.....	P-4	ARA021 .....	P-49
AA3021 SERIES.....	P-14	APDA3020P3C-P22 .....	P-44	ARB011 .....	P-49
AA3527A SERIES .....	P-14	APF3236SEEZGQBDC.....	P-21	ARB031A.....	P-49
AA3528 SERIES.....	P-15	APFA2507 SERIES .....	P-19	ATIR0511S .....	P-48
AA3528LSECKT/J3.....	P-5	APFA2507LQBDSEEZGKC .....	P-6	ATIR0711S .....	P-47
AA3528SF4S-R.....	P-41	APFA3010 SERIES .....	P-20	ATIR0711S-F .....	P-47
AA3528xxx09 SERIES .....	P-23	APFA3010LSEEZGKBKC.....	P-7	ATIR0721DS.....	P-47
AA4040 SERIES.....	P-17	APFA3010R2G2C-C6-AMT .....	P-10	ATIR0811S .....	P-48
AA4040-AMT SERIES.....	P-10	APFA3011-AK13/F .....	P-20	ATIR0911S .....	P-48
AA4040P3C-P22 .....	P-45	APG0603 SERIES.....	P-10	WP1043 SERIES.....	P-28
AA4040SF4BT-P22 .....	P-41	APG0603-5MAV SERIES.....	P-7	WP113 SERIES.....	P-27
AAA3528LSEEZGKBKS.....	P-7	APG1005 SERIES.....	P-11	WP130WCP/2 SERIES .....	P-37
AAA3528SEEZGKBKS.....	P-22	APG1005-5MAV SERIES .....	P-7	WP130WDT/ SERIES .....	P-35
AAA3528xxx09 SERIES .....	P-23	APG1608 SERIES.....	P-11	WP132X SERIES .....	P-25
AAAF5050-MC-K12.....	P-33	APGF0606 SERIES.....	P-8	WP1384AD/ SERIES.....	P-35
AB354NT.....	P-51	APGF1012GBRC-07 .....	P-8	WP1503 SERIES.....	P-26
AB356N2T.....	P-51	APHB1608 SERIES.....	P-17	WP1503CB/ SERIES.....	P-36
AB356N6T.....	P-51	APHB1608-AMT SERIES.....	P-9	WP1533BQ/ SERIES .....	P-35
AB357NT.....	P-51	APHB1608LZGKSURKC.....	P-5	WP154A4 SERIES .....	P-29
AB814B .....	P-50	APHBM2012 SERIES.....	P-18	WP154A4AVS/ SERIES .....	P-36
AB814B-B.....	P-50	APHBM2012LSURKZGKC.....	P-5	WP3A10 SERIES .....	P-25
AB817A-B.....	P-50	APHCM2012 SERIES .....	P-12	WP3DP3BT .....	P-45
AB817B-B.....	P-50	APHF1608LSEEQBZGKC.....	P-6	WP3DP3BT/BD-P22.....	P-45
AB817D-B.....	P-50	APHF1608SEEQBZGKC .....	P-17	WP3DPD1BT/BD.....	P-43
ACSX02-41 SERIES .....	P-31	APHHS1005 SERIES .....	P-11	WP3V SERIES .....	P-28
ACSX03-41 SERIES .....	P-31	APHHS1005L SERIES .....	P-3	WP424SYDTK.....	P-27
ACSX04-41 SERIES .....	P-32	APHM1608VRBXF/A-5MAV .....	P-8	WP483SURDTK.....	P-27
ACSX56-41 SERIES .....	P-32	APL3015 SERIES.....	P-12	WP57 SERIES.....	P-28
AM2520F3C03-P22.....	P-41	APPA3010SF4C-P22 .....	P-40	WP59 SERIES.....	P-29
AM2520PD1BT03.....	P-43	APS3227SP1C-P22 .....	P-47	WP59BL/ SERIES .....	P-36
AM2520xxx03 SERIES.....	P-22	APT1608 SERIES .....	P-11	WP710A10 SERIES .....	P-25
AM2520xxx09 SERIES.....	P-22	APT1608-AMT SERIES.....	P-9	WP710A10F3BT.....	P-42
AM4457F3C .....	P-41	APT1608F3C.....	P-39	WP710A10F3C.....	P-42
AM4457P3C-F-R .....	P-45	APT1608L SERIES .....	P-3	WP710A10L SERIES .....	P-29
AP1608P1C-P22 .....	P-44	APT1608VRCXF/A-5MAV .....	P-9	WP710A10SF4BT-P22 .....	P-42
AP2012P3C-P22 .....	P-44	APT2012 SERIES .....	P-12	WP7113 SERIES.....	P-26
AP2012SF4C.....	P-39	APT2012F3C.....	P-39	WP7113F3BT .....	P-42
APA1606 SERIES .....	P-15	APT2012L SERIES .....	P-3	WP7113F3C .....	P-42
APA1606SF4C-P22.....	P-39	APT2012P3BT.....	P-44	WP7113L SERIES.....	P-29
APA2107 SERIES .....	P-16	APT3216 SERIES .....	P-13	WP7113P3C.....	P-45
APA2107L SERIES.....	P-4	APT3216LSECK/J3-PRV .....	P-4	WP7113PD1BT/BD-P22.....	P-43
APA3010 SERIES .....	P-16	APTB1612 SERIES.....	P-18	WP7113SF4C.....	P-42
APA3010F3C-GX .....	P-40	APTB1615 SERIES.....	P-18	WP7113SF6C.....	P-42
APA3010P3BT-GX .....	P-44	APTD1608 SERIES.....	P-12	WP7113SF7C.....	P-42
APA3010SF4C .....	P-40	APTD1608L SERIES .....	P-3	WP793SRD/J4 .....	P-26
APB3025SURKCGKC-F01.....	P-20	APTD2012L SERIES .....	P-4	WP813 SERIES.....	P-26
APB3227SURKCGKC .....	P-21	APTD3216 SERIES .....	P-13	WP914SURDK .....	P-27
APBA3010 SERIES.....	P-19	APTD3216F3C-P22.....	P-40	WP934CB/ SERIES.....	P-35
APBD3224 SERIES.....	P-21	APTD3216LSURCK .....	P-5	WP934EB/2 SERIES.....	P-36
APBD3224L SERIES.....	P-6	APTD3216P3C-P22 .....	P-45	WP934EW/ SERIES.....	P-35
APBDA3020 SERIES .....	P-21	APTD3216SF4C.....	P-40	WP934MD/2 SERIES.....	P-37
APBL3025SURKCGK-F01 .....	P-20	APTF1616 SERIES .....	P-18	WP934SA/3 SERIES.....	P-37
APD3224 SERIES.....	P-13	APTF1616LSEEZGKBKC.....	P-6	WP934SB/4 SERIES.....	P-37
APDA1806 SERIES.....	P-15	APTL3216 SERIES .....	P-13	WP937 SERIES.....	P-28
APDA3020 SERIES.....	P-16	APTL3216xxx01 SERIES.....	P-23		