

# XLamp® XFL LEDs



## PRODUCT DESCRIPTION

XLamp® XFL LEDs are the first LED family that is fully optimized for flashlights and other portable lighting applications in terms of light output, optical performance and value. The XFL LED family is offered in three performance levels that are designed for specific flashlight output targets of 5K, 8K and 10K lm with typical optical and thermal losses taken into account. With a 90% smaller light-emitting surface (LES) than competing solutions with similar light output, XFL LEDs create portable lights with better looking beam shapes, less color variations and longer throw distance.

XLamp XFL LEDs are optimized for high-output flashlight and other portable lighting applications.

## FEATURES

- Available in ANSI white bins at 6500 K, 5700 K & 5000 K CCT
- Binned at 25 °C
- Available in 70 and 80 (XFL05K only) CRI minimum options
- Unlimited floor life at ≤ 30 °C/85% RH
- Reflow solderable - JEDEC J-STD-020C compatible
- Electrically neutral thermal path
- RoHS and REACH compliant
- UL® recognized component (E349212)

## TABLE OF CONTENTS

Characteristics .....	2
Maximum Current vs. Junction Temperature .....	3
Flux Characteristics .....	5
Relative Spectral Power Distribution .....	6
Relative Flux vs. Junction Temperature.....	6
Electrical Characteristics.....	8
Relative Flux vs. Current .....	9
Typical Spatial Distribution.....	11
Performance Groups - Chromaticity .....	13
ANSI Cool and Neutral White Kits Plotted on ANSI Standard Chromaticity Regions....	13
Standard Chromaticity Kits .....	14
Bin and Order Code Formats.....	14
Reflow Soldering Characteristics.....	15
Notes .....	16
Mechanical Dimensions .....	17
Tape and Reel.....	19
Packaging.....	23



## CHARACTERISTICS

Characteristics	Unit	Minimum	Typical	Maximum
Thermal resistance, junction to solder point - XFL05K	°C/W		0.2	
Thermal resistance, junction to solder point - XFL08K	°C/W		0.1	
Thermal resistance, junction to solder point - XFL10K	°C/W		0.1	
Viewing angle (FWHM) - XFL05K	degrees		140	
Viewing angle (FWHM) - XFL08K	degrees		150	
Viewing angle (FWHM) - XFL10K	degrees		150	
Temperature coefficient of voltage - XFL05K	mV/°C		-2.6	
Temperature coefficient of voltage - XFL08K	mV/°C		-2.8	
Temperature coefficient of voltage - XFL10K	mV/°C		-2.9	
Reverse voltage	V			5
Forward current - XFL05K*	A			15
Forward current - XFL08K*	A			27
Forward current - XFL10K*	A			32
Forward voltage (@ 1750 mA, 25 °C) - XFL05K	V		5.6	6.1
Forward voltage (@ 3150 mA, 25 °C) - XFL08K	V		5.7	6.1
Forward voltage (@ 4200 mA, 25 °C) - XFL10K	V		5.7	6.1
LED junction temperature	°C		25	150

### Note

- Thermal resistance measurement was performed per the JEDEC JESD51-14 standard. See the [Thermal Resistance Measurement application note](#) for more details.
- \* Refer to the Maximum Current vs. Junction Point Temperature section.

## MAXIMUM CURRENT VS. JUNCTION TEMPERATURE

XFL LEDs should be driven at maximum current for only up to 60 seconds at a time with design measures taken to ensure the junction temperature ( $T_j$ ) never exceeds the  $T_j$  value at the operating drive current as shown in the Maximum Current vs. Junction Temperature graphs below. For applications requiring longer operating lifetime, please refer to the [LED Reliability Overview document](#) for guidance on drive currents for which XFL LEDs have been tested for hours of continuous operation.

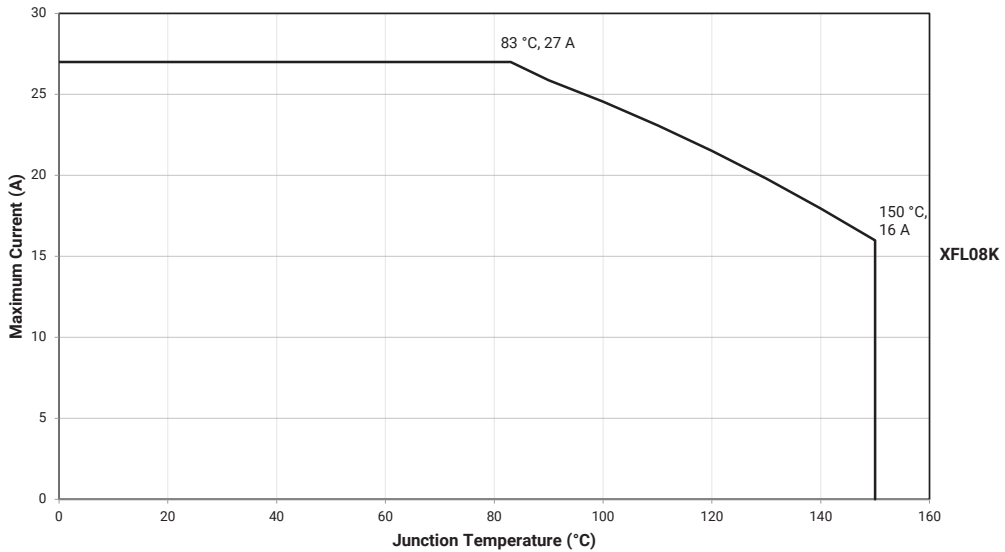
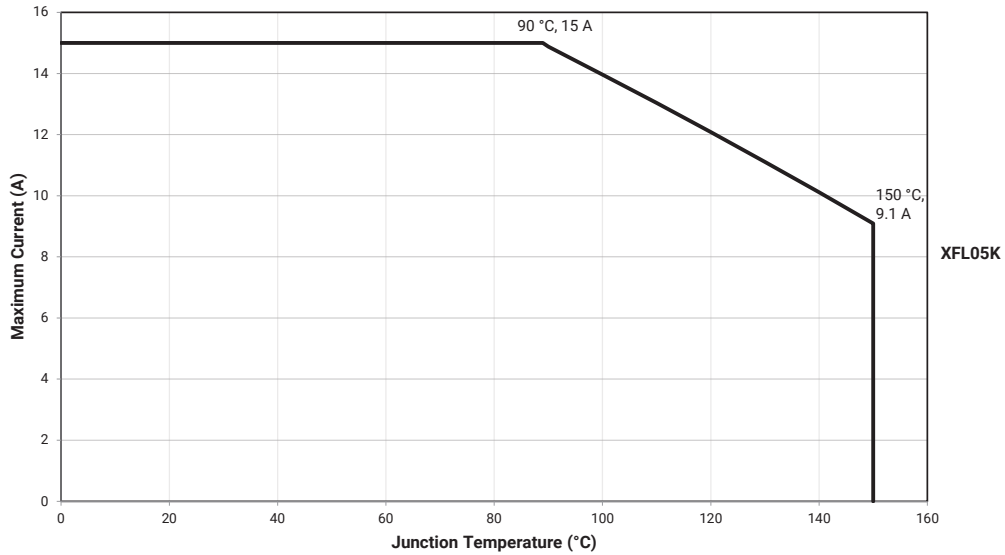

### MAXIMUM CURRENT VS. JUNCTION TEMPERATURE - CONTINUED

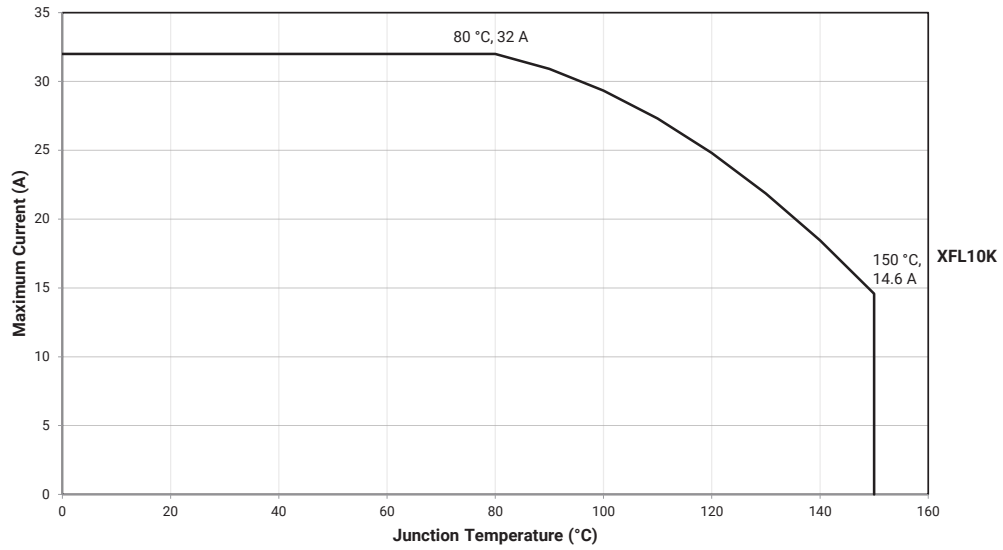

## FLUX CHARACTERISTICS ( $T_j = 25\text{ }^\circ\text{C}$ )

The following tables provide order codes for XLamp XFL LEDs. For a complete description of the order code nomenclature, please see the Bin and Order Code Formats section (page 14).

### XFL05K

CCT	CRI	Minimum Luminous Flux (lm) @ 1750 mA	Typical Luminous Flux (lm) @ 1750 mA	Order Code
6500 K	70	1500	1750	XFL05K-00-0000-0B0B0A0E1
5700 K	70	1525	1775	XFL05K-00-0000-0B0B0A0E2
5000 K	70	1550	1800	XFL05K-00-0000-0B0B0A0E3
	80	1400	1650	XFL05K-00-0000-0B0H0A0E3

### XFL08K

CCT	CRI	Minimum Luminous Flux (lm) @ 3150 mA	Typical Luminous Flux (lm) @ 3150 mA	Order Code
6500 K	70	2700	3150	XFL08K-00-0000-0B0B0A0E1
5700 K	70	2750	3200	XFL08K-00-0000-0B0B0A0E2
5000 K	70	2800	3250	XFL08K-00-0000-0B0B0A0E3

### XFL10K

CCT	CRI	Minimum Luminous Flux (lm) @ 4200 mA	Typical Luminous Flux (lm) @ 4200 mA	Order Code
6500 K	70	3500	4100	XFL10K-00-0000-0B0B0A0E1
5700 K	70	3600	4200	XFL10K-00-0000-0B0B0A0E2
5000 K	70	3700	4300	XFL10K-00-0000-0B0B0A0E3

### Notes

- Cree LED maintains a tolerance of  $\pm 7\%$  on flux and power measurements,  $\pm 0.015$  on chromaticity (CCx, CCy) measurements and a tolerance of  $\pm 2$  on CRI measurements. See the Measurements section (page 16).

### RELATIVE SPECTRAL POWER DISTRIBUTION - COOL WHITE

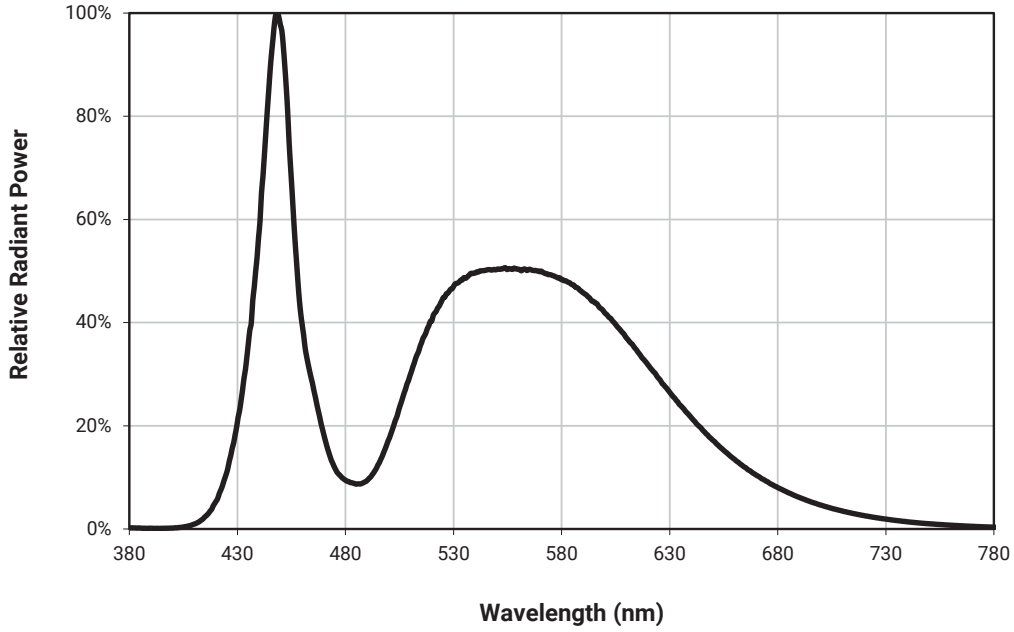

### RELATIVE FLUX VS. JUNCTION TEMPERATURE

$I_F = 1750 \text{ mA}$

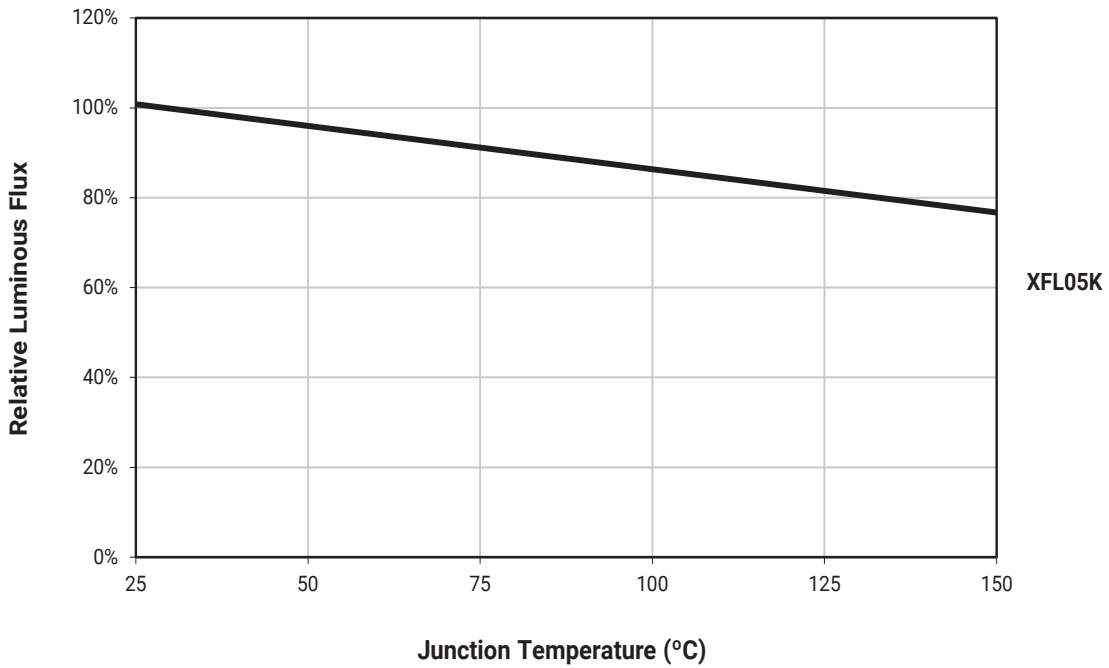

RELATIVE FLUX VS. JUNCTION TEMPERATURE - CONTINUED

$I_F = 3150 \text{ mA}$

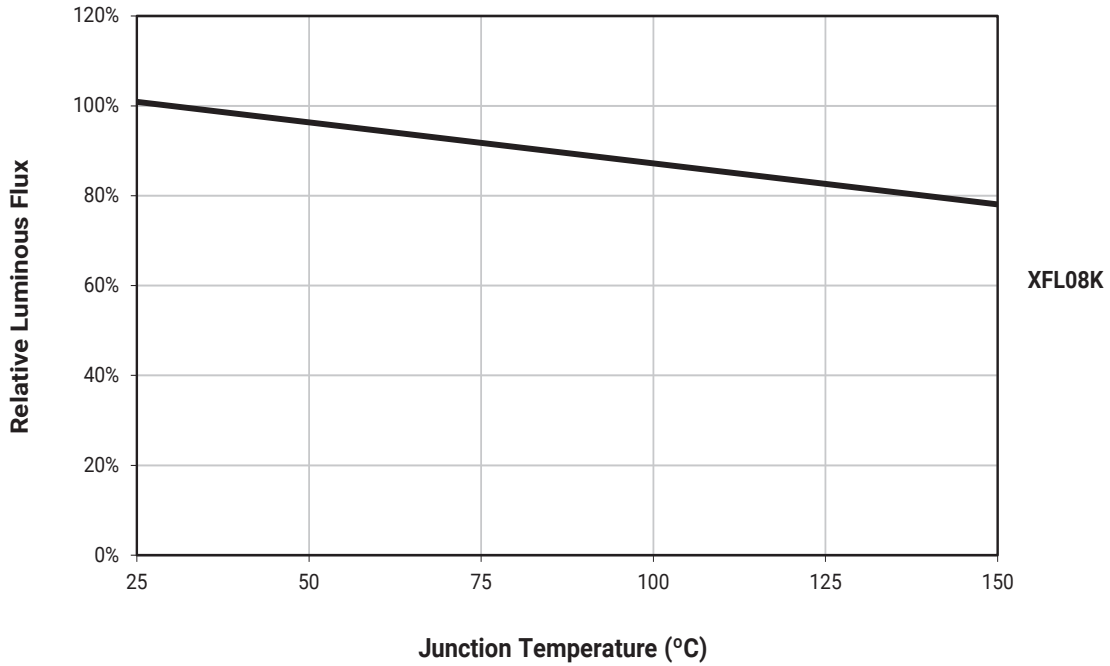

$I_F = 4200 \text{ mA}$

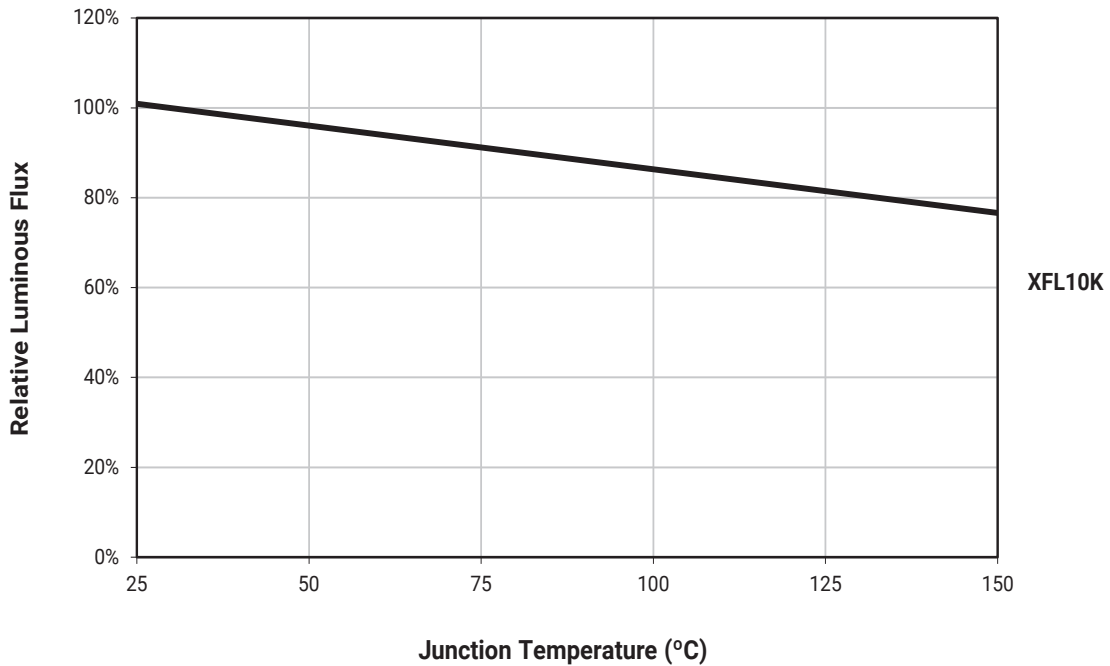

### ELECTRICAL CHARACTERISTICS

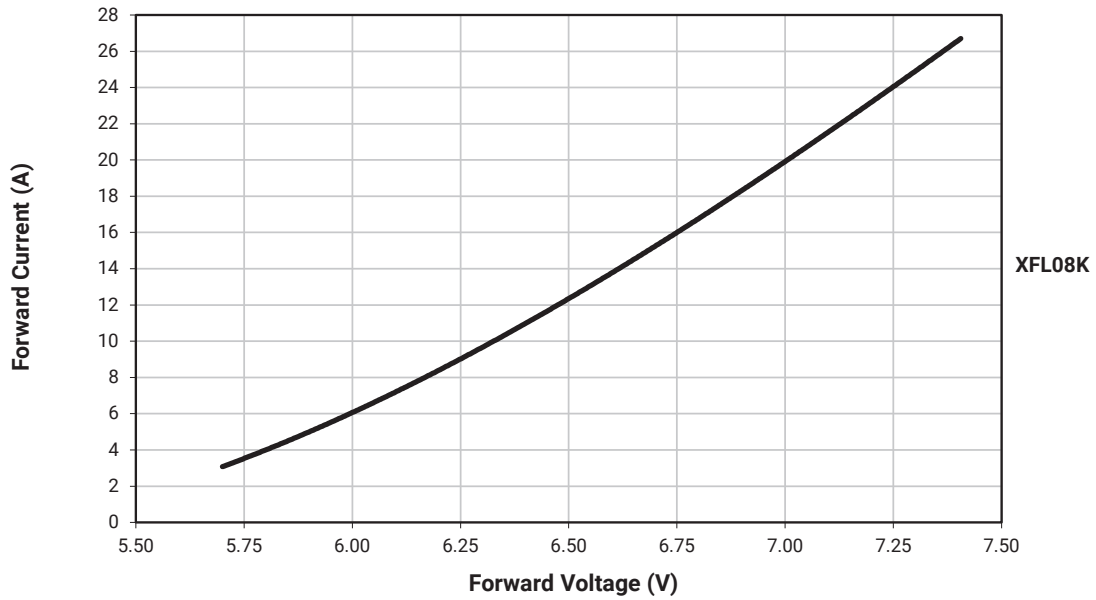
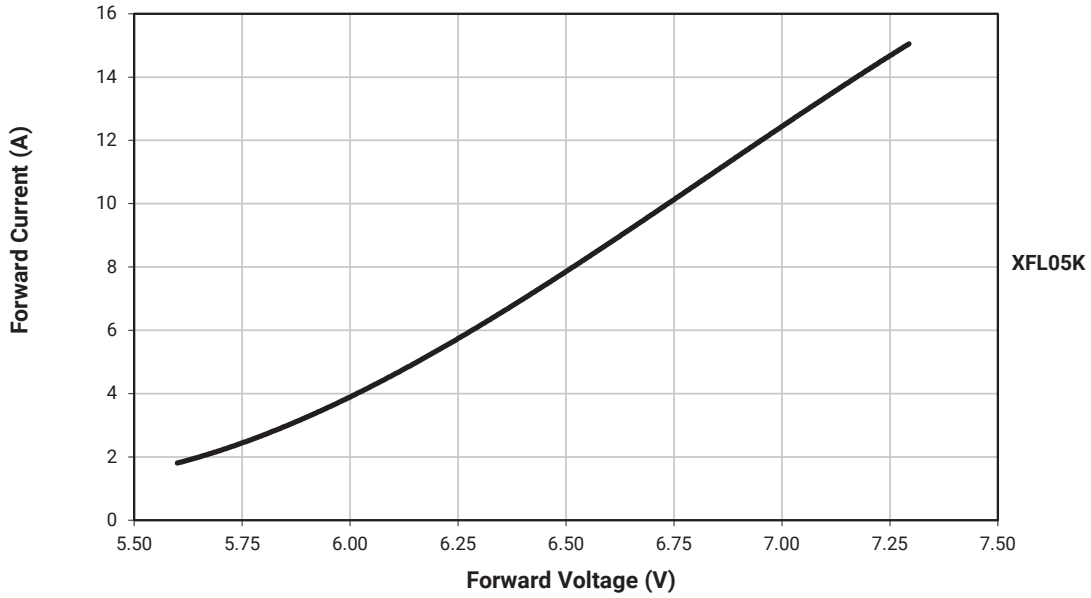



ELECTRICAL CHARACTERISTICS - CONTINUED

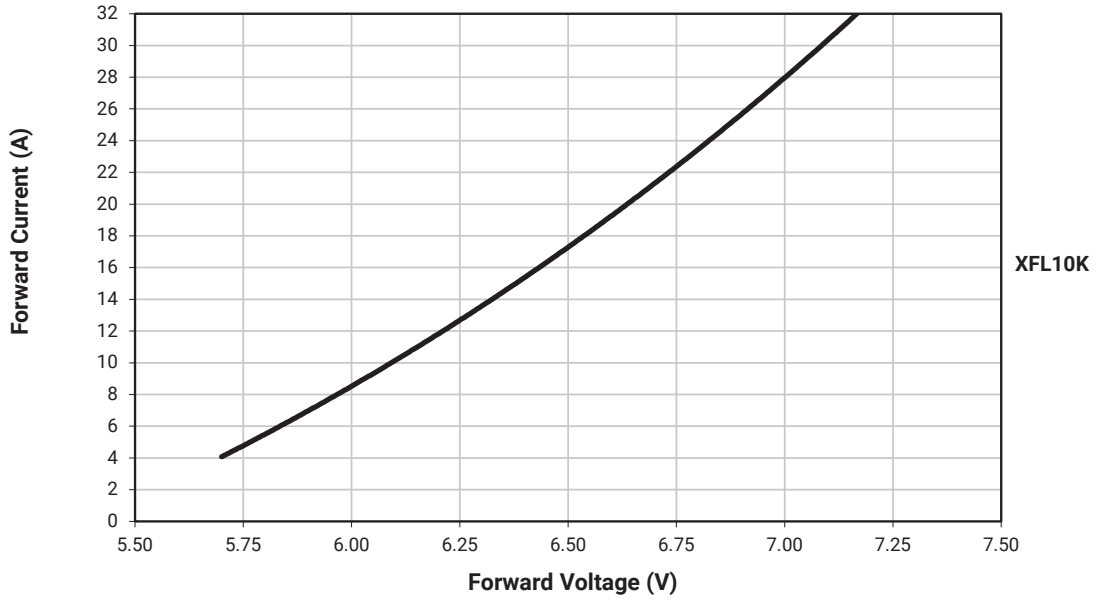

RELATIVE FLUX VS. CURRENT ( $T_j = 25\text{ }^\circ\text{C}$ )

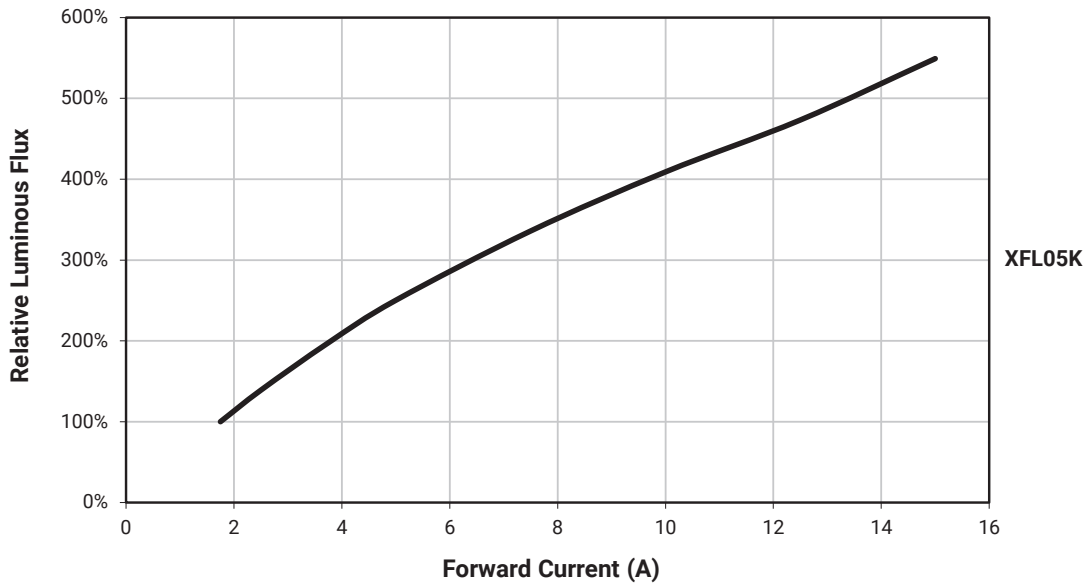

RELATIVE FLUX VS. CURRENT ( $T_j = 25\text{ }^\circ\text{C}$ ) - CONTINUED

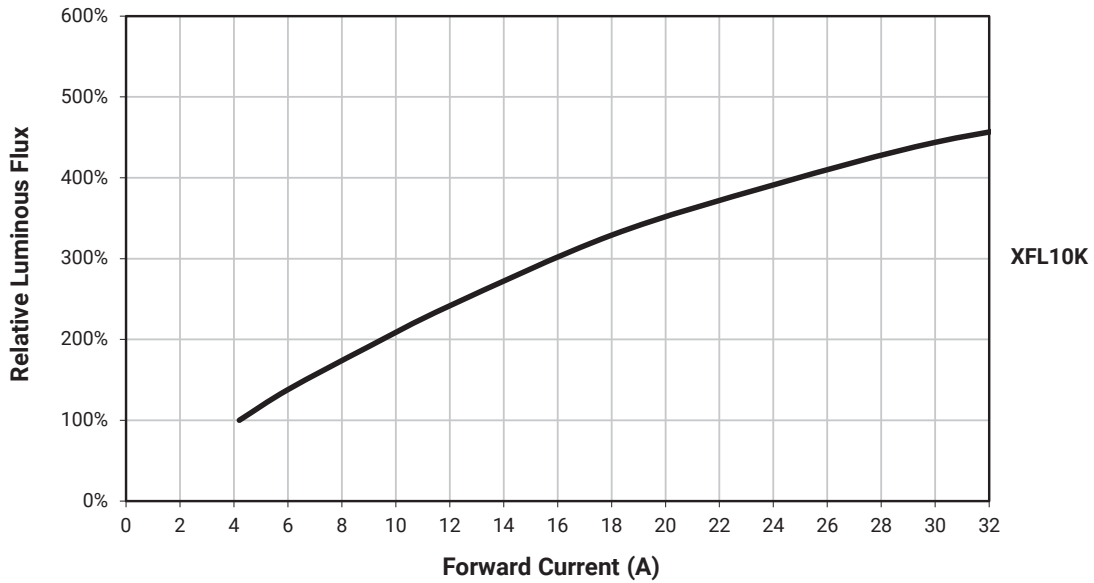
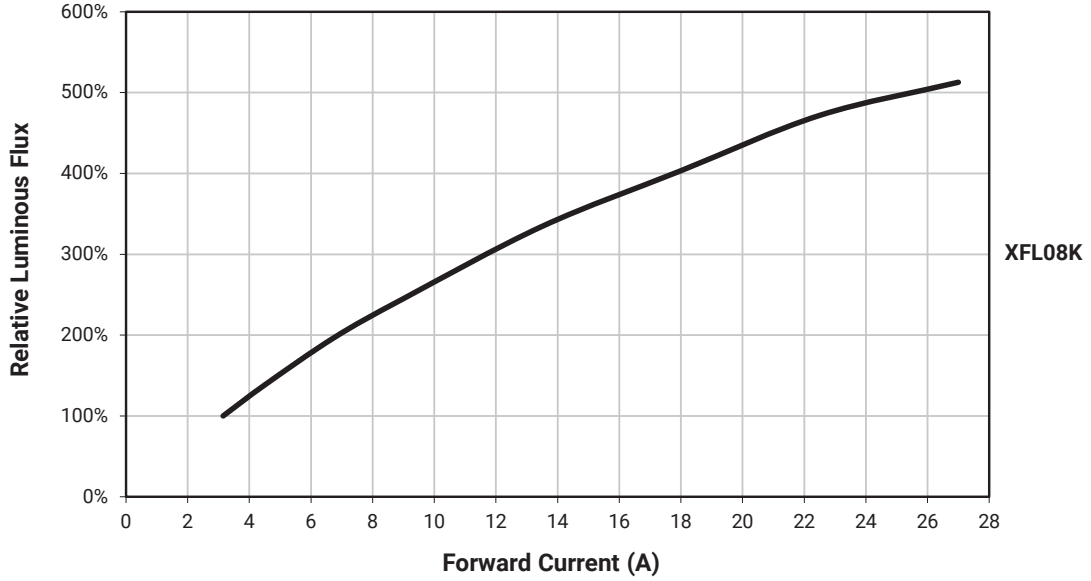

TYPICAL SPATIAL DISTRIBUTION

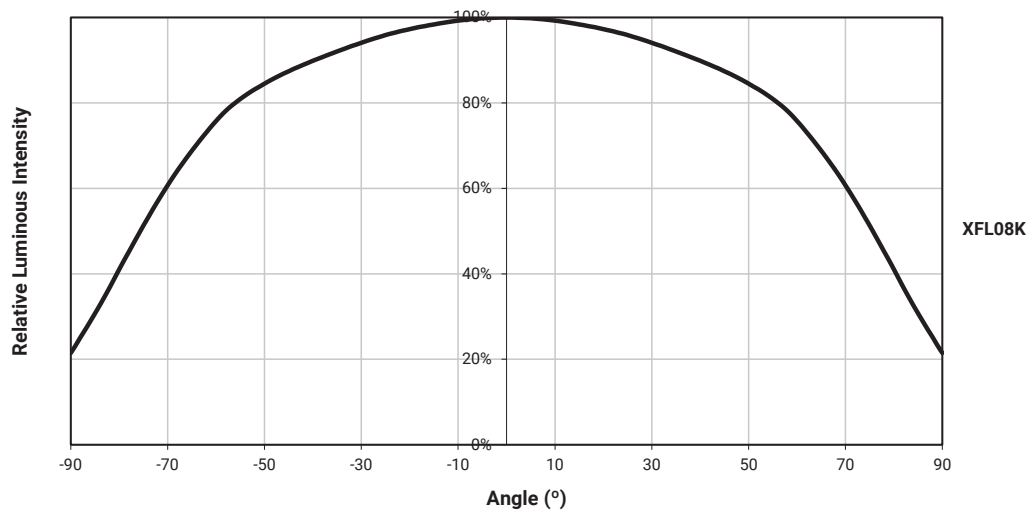
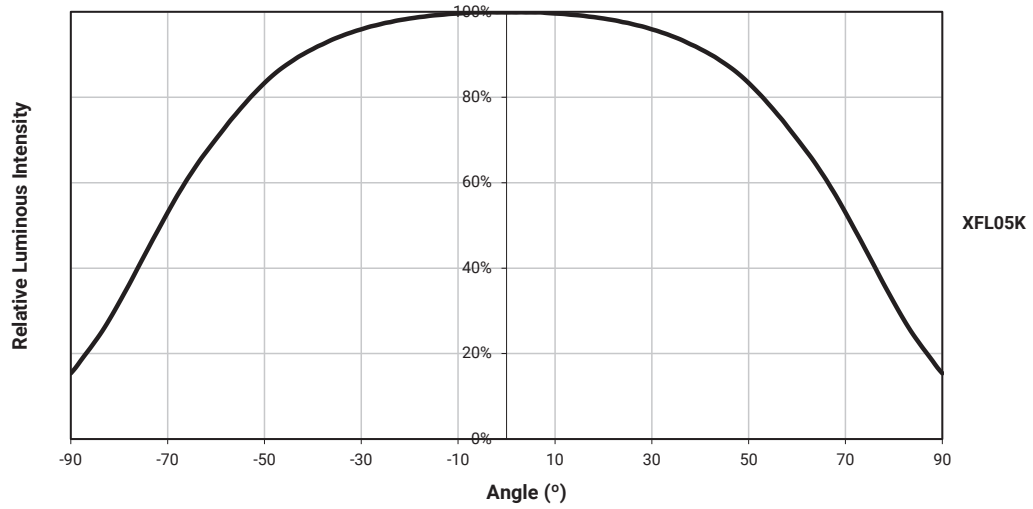

TYPICAL SPATIAL DISTRIBUTION - CONTINUED

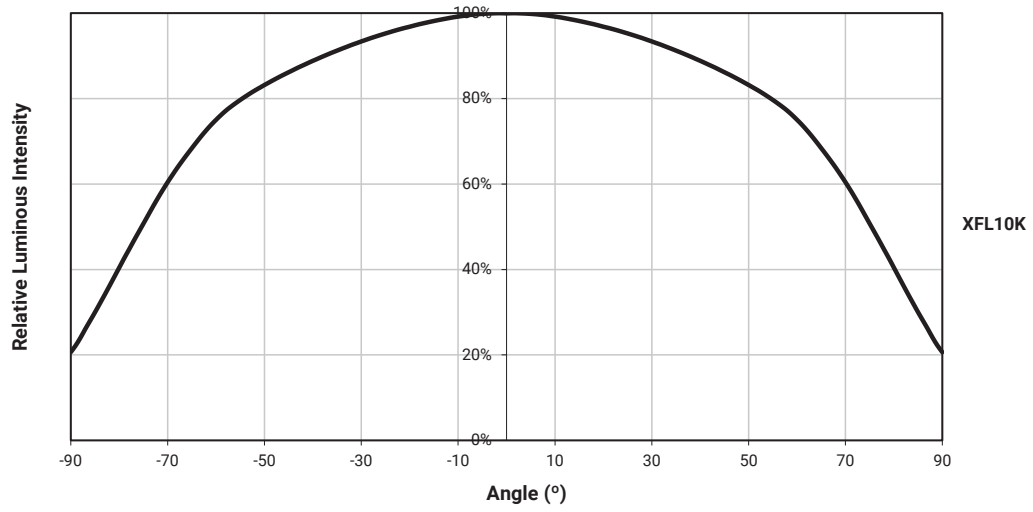

PERFORMANCE GROUPS - CHROMATICITY ( $T_j = 25\text{ }^\circ\text{C}$ )

Region	x	y	Region	x	y	Region	x	y	Region	x	y
1A	0.3048	0.3207	1B	0.3028	0.3304	1C	0.3115	0.3391	1D	0.3130	0.3290
	0.3130	0.3290		0.3115	0.3391		0.3205	0.3481		0.3213	0.3373
	0.3144	0.3186		0.3130	0.3290		0.3213	0.3373		0.3221	0.3261
	0.3068	0.3113		0.3048	0.3207		0.3130	0.3290		0.3144	0.3186
2A	0.3215	0.3350	2B	0.3207	0.3462	2C	0.3290	0.3538	2D	0.3290	0.3417
	0.3290	0.3417		0.3290	0.3538		0.3376	0.3616		0.3371	0.3490
	0.3290	0.3300		0.3290	0.3417		0.3371	0.3490		0.3366	0.3369
	0.3222	0.3243		0.3215	0.3350		0.3290	0.3417		0.3290	0.3300
3A	0.3371	0.3490	3B	0.3376	0.3616	3C	0.3463	0.3687	3D	0.3451	0.3554
	0.3451	0.3554		0.3463	0.3687		0.3551	0.3760		0.3533	0.3620
	0.3440	0.3427		0.3451	0.3554		0.3533	0.3620		0.3515	0.3487
	0.3366	0.3369		0.3371	0.3490		0.3451	0.3554		0.3440	0.3427

ANSI COOL AND NEUTRAL WHITE KITS PLOTTED ON ANSI STANDARD CHROMATICITY REGIONS

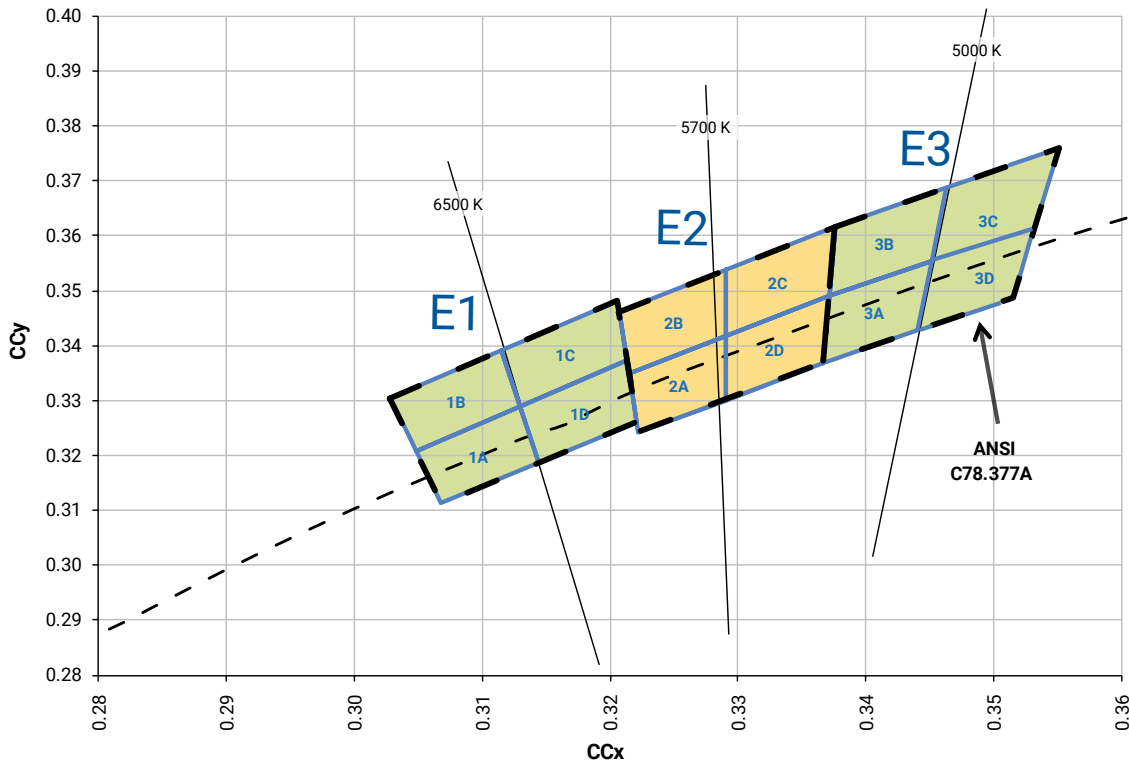

## STANDARD CHROMATICITY KITS

Color	CCT	Kit	Chromaticity Bins
Cool White	6500 K	E1	1A, 1B, 1C, 1D
	5700 K	E2	2A, 2B, 2C, 2D
Neutral White	5000 K	E3	3A, 3B, 3C, 3D

## BIN AND ORDER CODE FORMATS

Bin codes and order codes are configured as follows.

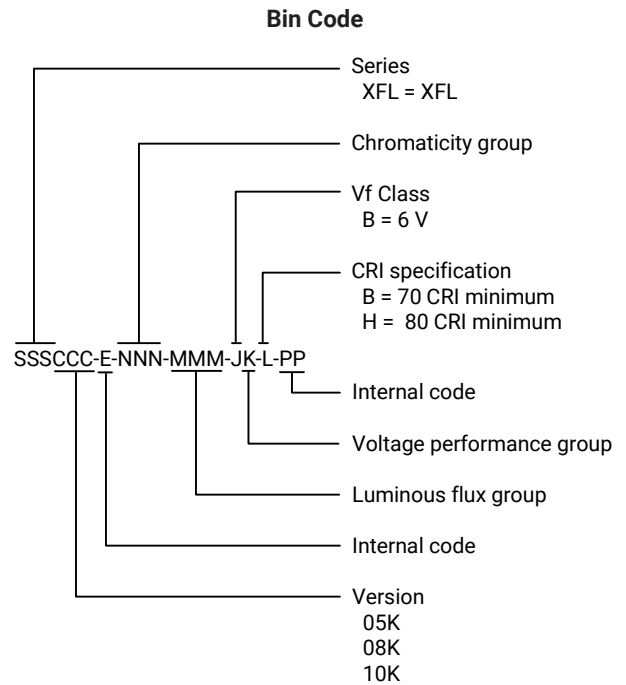
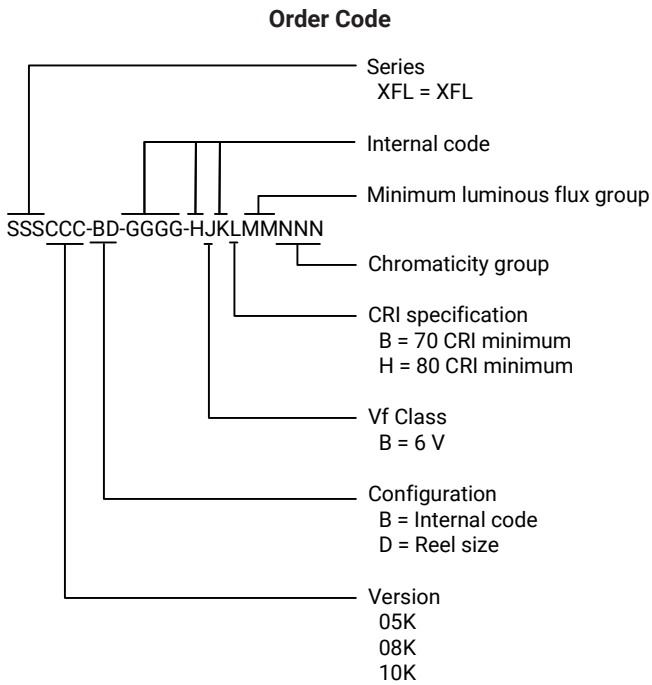

## REFLOW SOLDERING CHARACTERISTICS

In testing, Cree LED has found XLamp XFL LEDs to be compatible with JEDEC J-STD-020C, using the parameters listed below. As a general guideline, Cree LED recommends that users follow the recommended soldering profile provided by the manufacturer of the solder paste used, and therefore it is the lamp or luminaire manufacturer’s responsibility to determine applicable soldering requirements.

Note that this general guideline may not apply to all PCB designs and configurations of reflow soldering equipment.

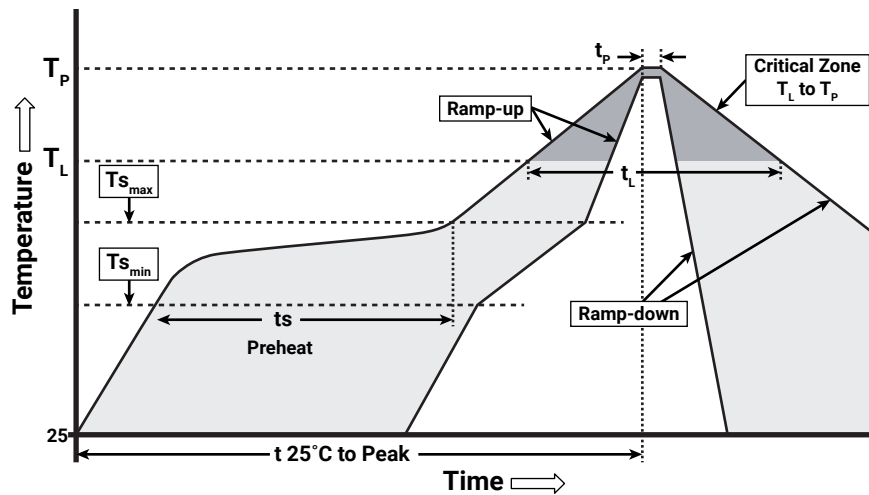

IPC/JEDEC J-STD-020C

Profile Feature	Lead-Free Solder
Average Ramp-Up Rate ( $T_{s_{max}}$ to $T_p$ )	1.2 °C/second
Preheat: Temperature Min ( $T_{s_{min}}$ )	120 °C
Preheat: Temperature Max ( $T_{s_{max}}$ )	170 °C
Preheat: Time ( $t_{s_{min}}$ to $t_{s_{max}}$ )	65-150 seconds
Time Maintained Above: Temperature ( $T_l$ )	217 °C
Time Maintained Above: Time ( $t_l$ )	45-90 seconds
Peak/Classification Temperature ( $T_p$ )	235 - 245 °C
Time Within 5 °C of Actual Peak Temperature ( $t_p$ )	20-40 seconds
Ramp-Down Rate	1 - 6 °C/second
Time 25 °C to Peak Temperature	4 minutes max.

Note: All temperatures refer to topside of the package, measured on the package body surface.

## NOTES

---

### Measurements

The luminous flux, radiant power, chromaticity, forward voltage and CRI measurements in this document are binning specifications only and solely represent product measurements as of the date of shipment. These measurements will change over time based on a number of factors that are not within Cree LED's control and are not intended or provided as operational specifications for the products. Calculated values are provided for informational purposes only and are not intended or provided as specifications.

### Pre-Release Qualification Testing

Please read the [LED Reliability Overview](#) for details on the qualification testing performed on XFL LEDs.

### Moisture Sensitivity

Cree LED recommends keeping XLamp LEDs in the provided, resealable moisture-barrier packaging (MBP) until immediately prior to soldering. Unopened MBPs that contain XLamp LEDs do not need special storage for moisture sensitivity.

Once the MBP is opened, XLamp XFL LEDs may be stored as MSL 1 per JEDEC J-STD-033, meaning they have unlimited floor life in conditions of  $\leq 30$  °C/85% relative humidity (RH). Regardless of the storage condition, Cree LED recommends sealing any unsoldered LEDs in the original MBP.

### RoHS Compliance

The levels of RoHS restricted materials in this product are below the maximum concentration values (also referred to as the threshold limits) permitted for such substances, or are used in an exempted application, in accordance with EU Directive 2011/65/EC (RoHS2), as implemented January 2, 2013. RoHS Declarations for this product can be obtained from your Cree LED representative or from the [Product Ecology](#) section of the Cree LED website.

### REACH Compliance

REACH substances of very high concern (SVHCs) information is available for this product. Since the European Chemical Agency (ECHA) has published notice of their intent to frequently revise the SVHC listing for the foreseeable future, please contact a Cree LED representative to insure you get the most up-to-date REACH SVHC Declaration. REACH banned substance information (REACH Article 67) is also available upon request.

### UL® Recognized Component

This product meets the requirements to be considered a UL Recognized Component with Level 4 enclosure consideration. The LED package or a portion thereof has been investigated as a fire and electrical enclosure per ANSI/UL 8750.

### Vision Advisory

**WARNING:** Do not look at an exposed lamp in operation. Eye injury can result. For more information about LEDs and eye safety, please refer to the [LED Eye Safety application note](#).



## MECHANICAL DIMENSIONS

Thermal vias, if present, are not shown on these drawings.  
 All measurements are  $\pm 0.13$  mm unless otherwise indicated.

### XFL05K

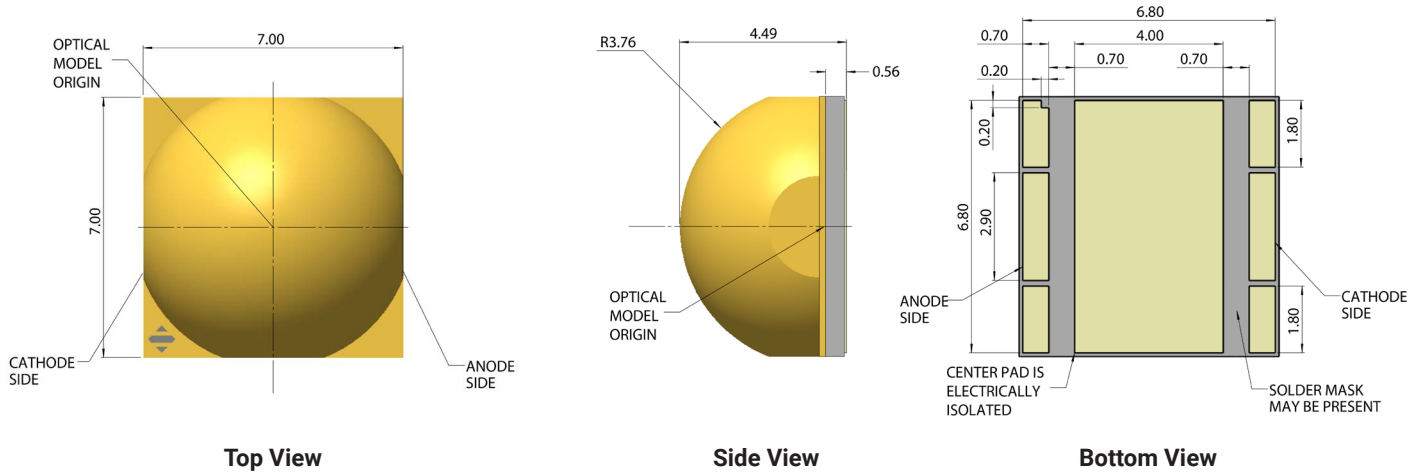

### XFL08K and XFL10K

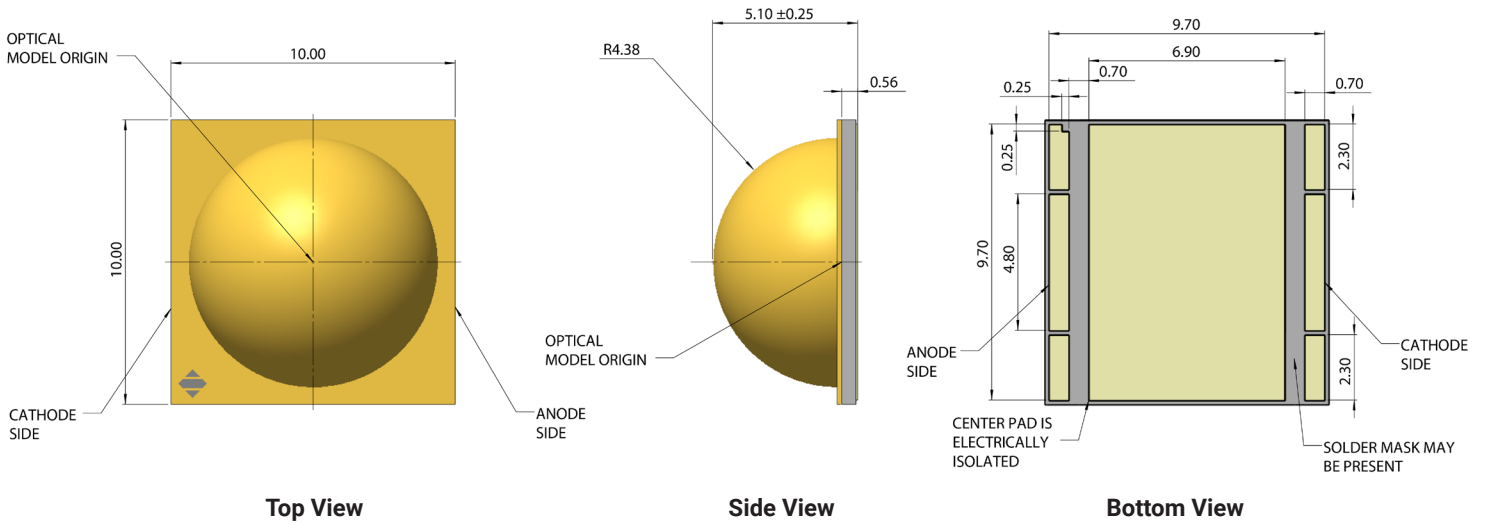

MECHANICAL DIMENSIONS - CONTINUED

XFL05K

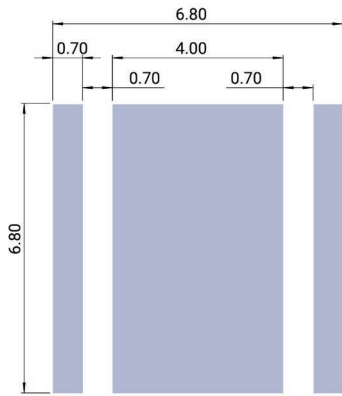

Recommended PCB Footprint

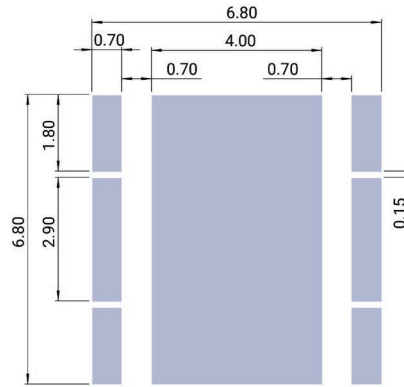

Recommended Solder Mask Opening

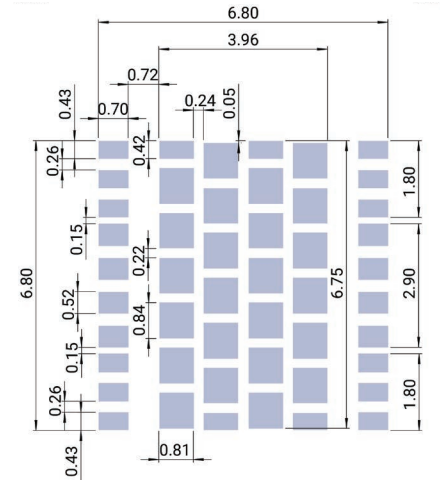

Recommended Stencil Opening

XFL08K and XFL10K

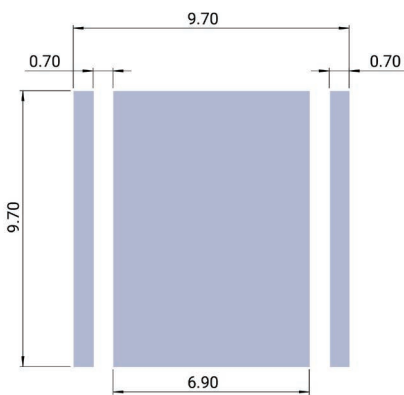

Recommended PCB Footprint

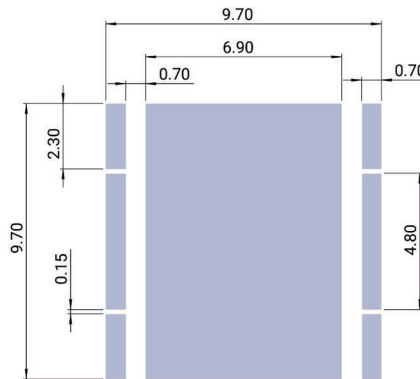

Recommended Solder Mask Opening

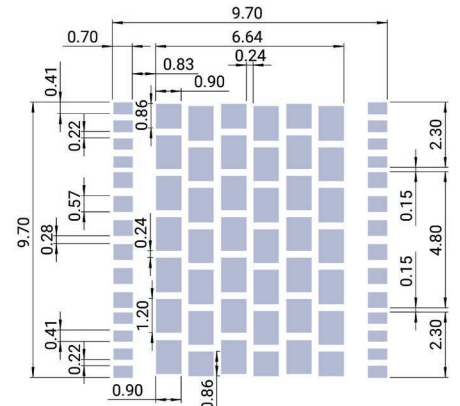

Recommended Stencil Opening

**TAPE AND REEL**

All Cree LED carrier tapes conform to EIA-481D, Automated Component Handling Systems Standard.

All dimensions in mm.

All measurements are  $\pm 0.13$  mm unless otherwise indicated.

**XFL05K**

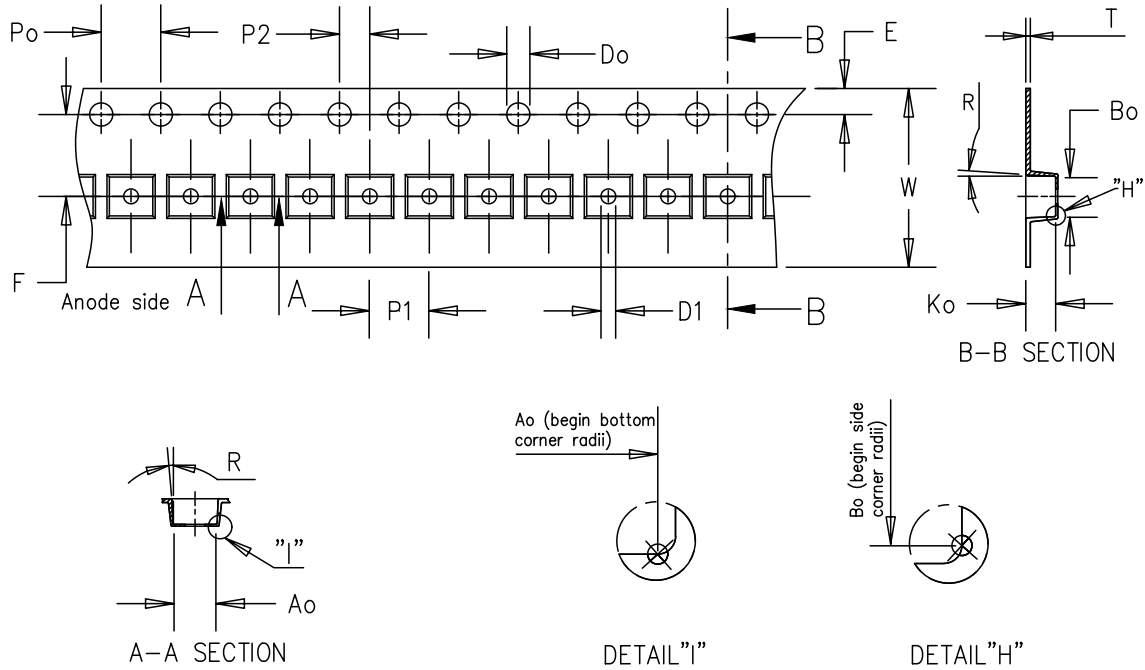

Item	Ao	Bo	Ko	Po	P1	P2	T	E	F	Do	D1	W	R
Dim.	7.40	7.40	4.60	4.00	12.00	2.00	0.36	1.75	7.50	1.50	1.50	16.00	5°

TAPE AND REEL - CONTINUED

XFL08K and XFL10K

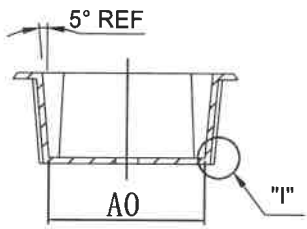
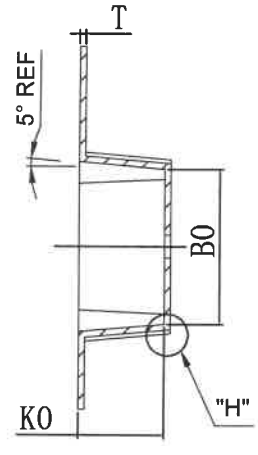
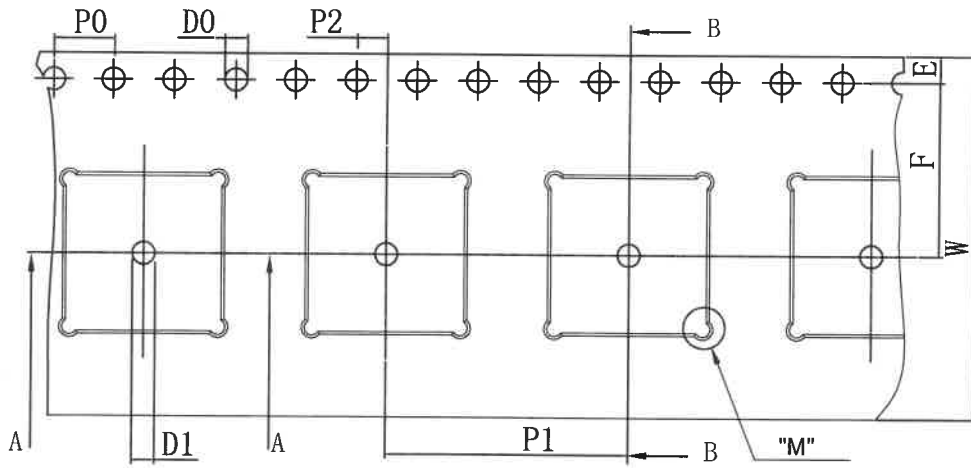

A-A SECTION

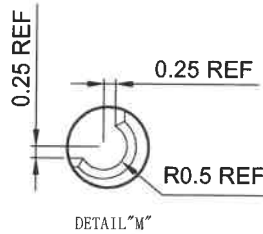

DETAIL "M"

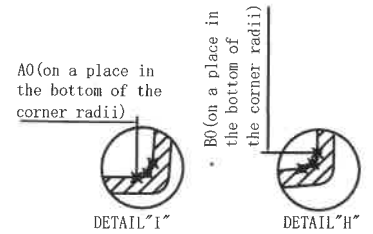

DETAIL "I"

DETAIL "H"

Item	A0	B0	K0	P0	P1	P2	T	E	F	D0	D1	W
Dim.	10.28	10.28	5.63	4.00	16.00	2.00	0.40	1.75	11.50	1.55	1.5 MIN	24.00

**TAPE AND REEL - CONTINUED**

XFL05K

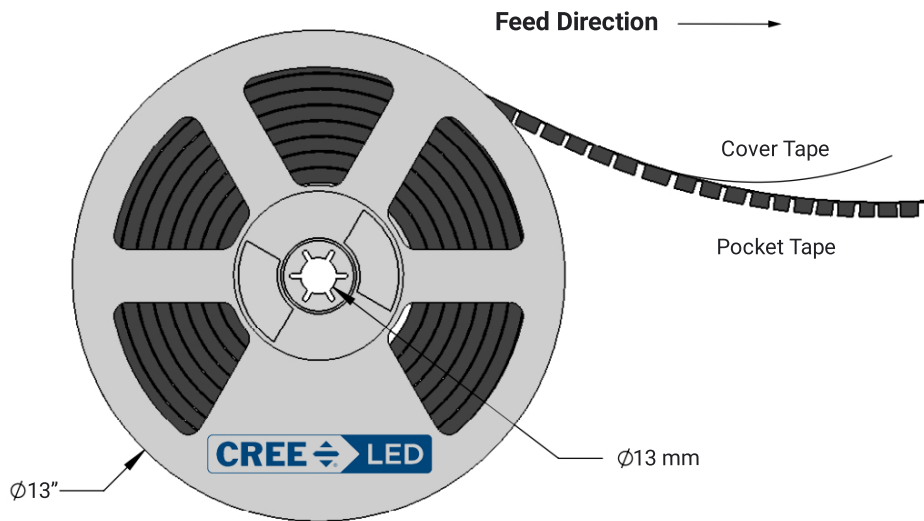
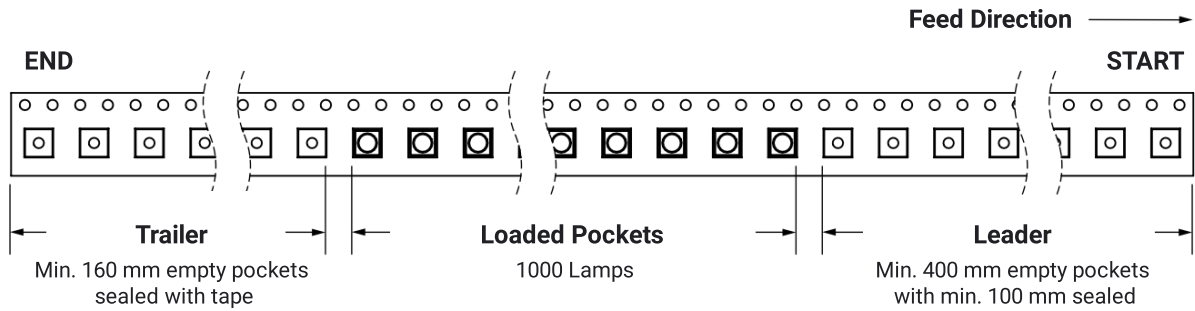

**TAPE AND REEL - CONTINUED**

**XFL08K and XFL10K**

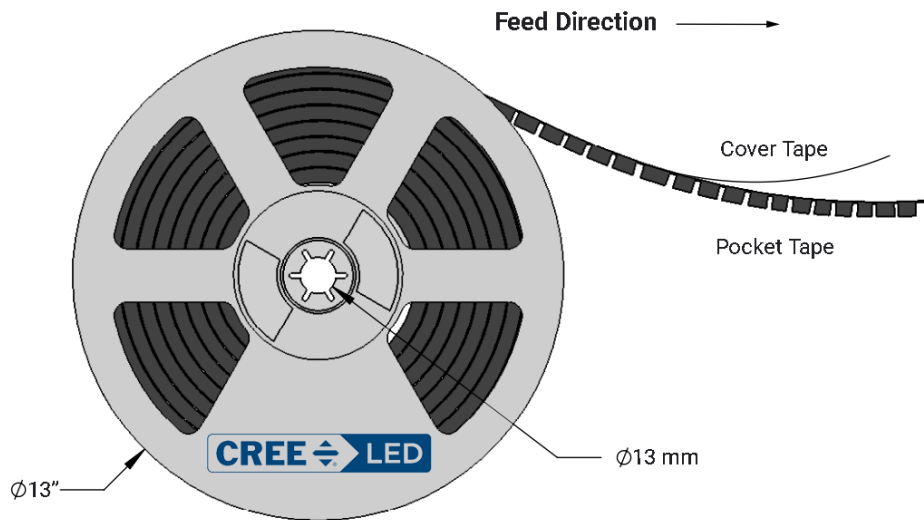
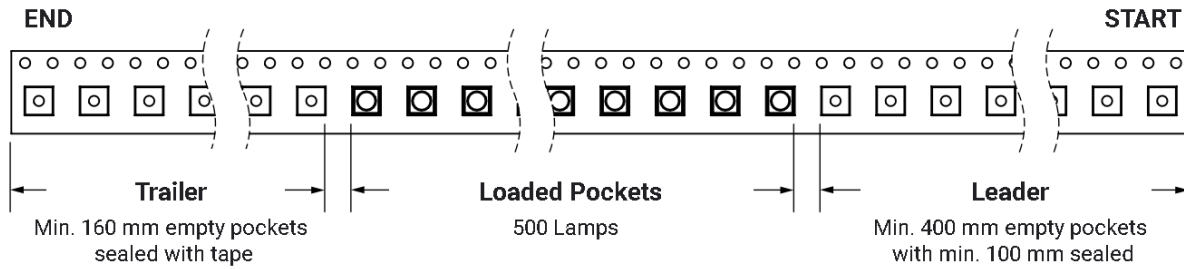

## PACKAGING

### Unpackaged Reel

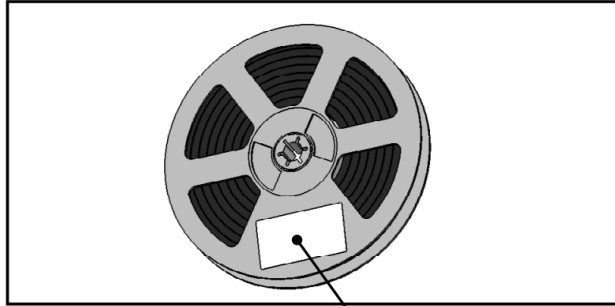

Label with Cree LED Bin Code, Quantity, Reel ID

### Packaged Reel

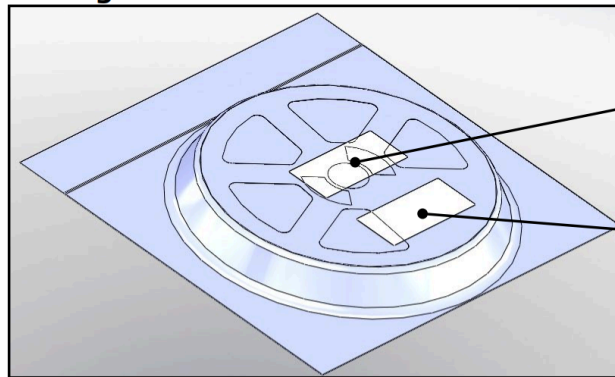

Label with Cree LED Order Code, Quantity, Reel ID, PO#

Label with Cree LED Bin Code, Quantity, Reel ID

### Boxed Reel

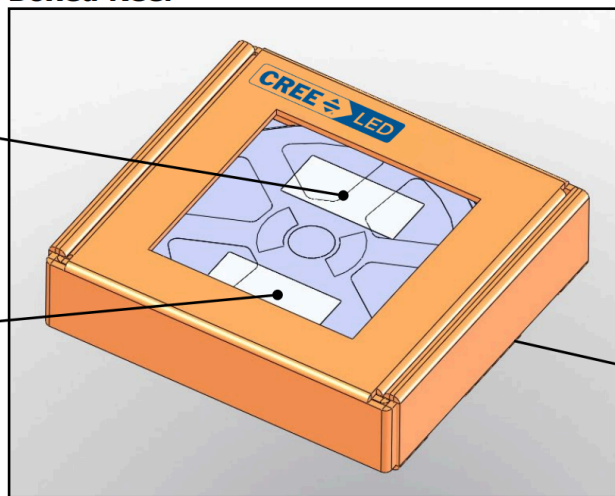

Label with Cree LED Order Code, Quantity, Reel ID, PO#

Label with Cree LED Bin Code, Quantity, Reel ID

Patent Label (on bottom of box)